

2nd Semester Geometry Review/Study Guide

1) Given  $\square ABCD$ , find:

- a.  $x$
- b.  $m\angle D$
- c.  $m\angle B$
- d.  $y$
- e.  $CD$
- f.  $AB$

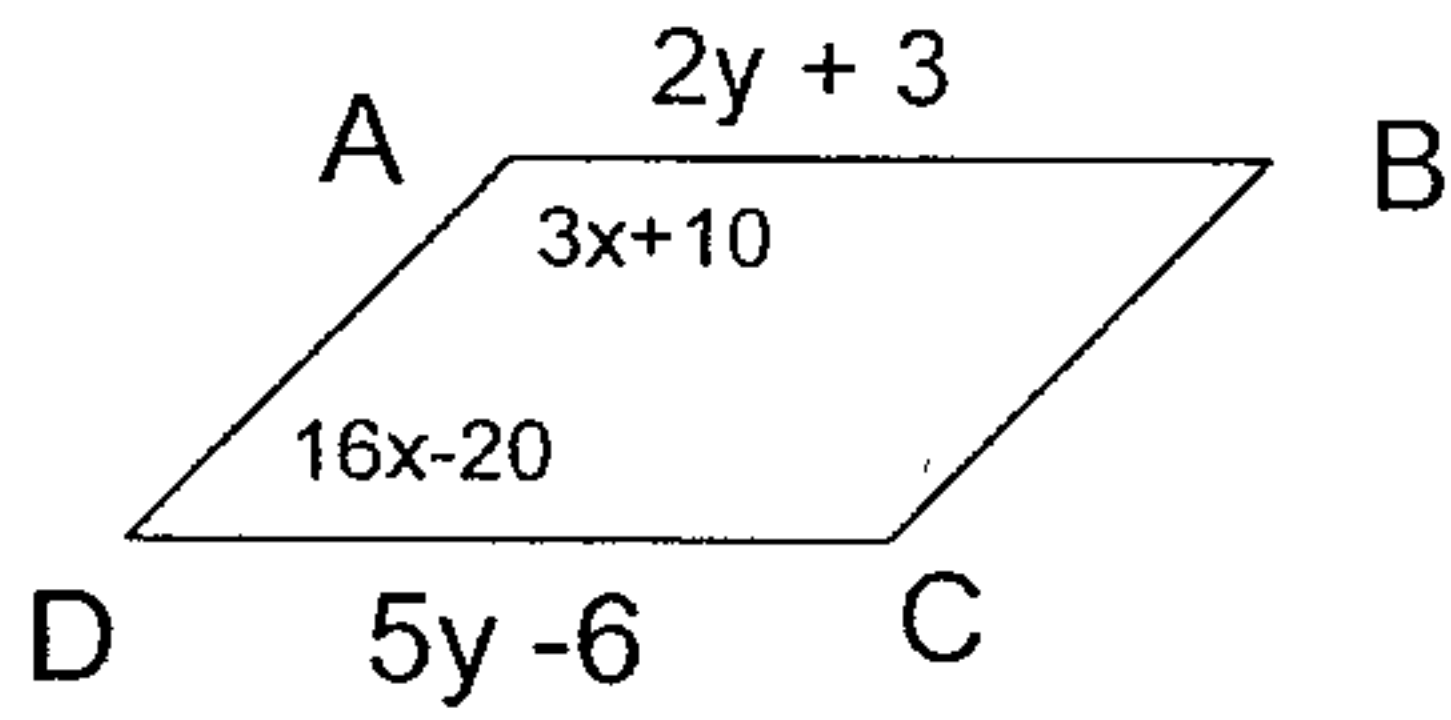

2) The perimeter of a rhombus is 60. The length of a side is:

- a. 30
- b. 20
- c. 15
- d. 12

3) If  $MNOP$  is a parallelogram, then  $m\angle M$  is:

- a. 12
- b. 55
- c. 70
- d. 110

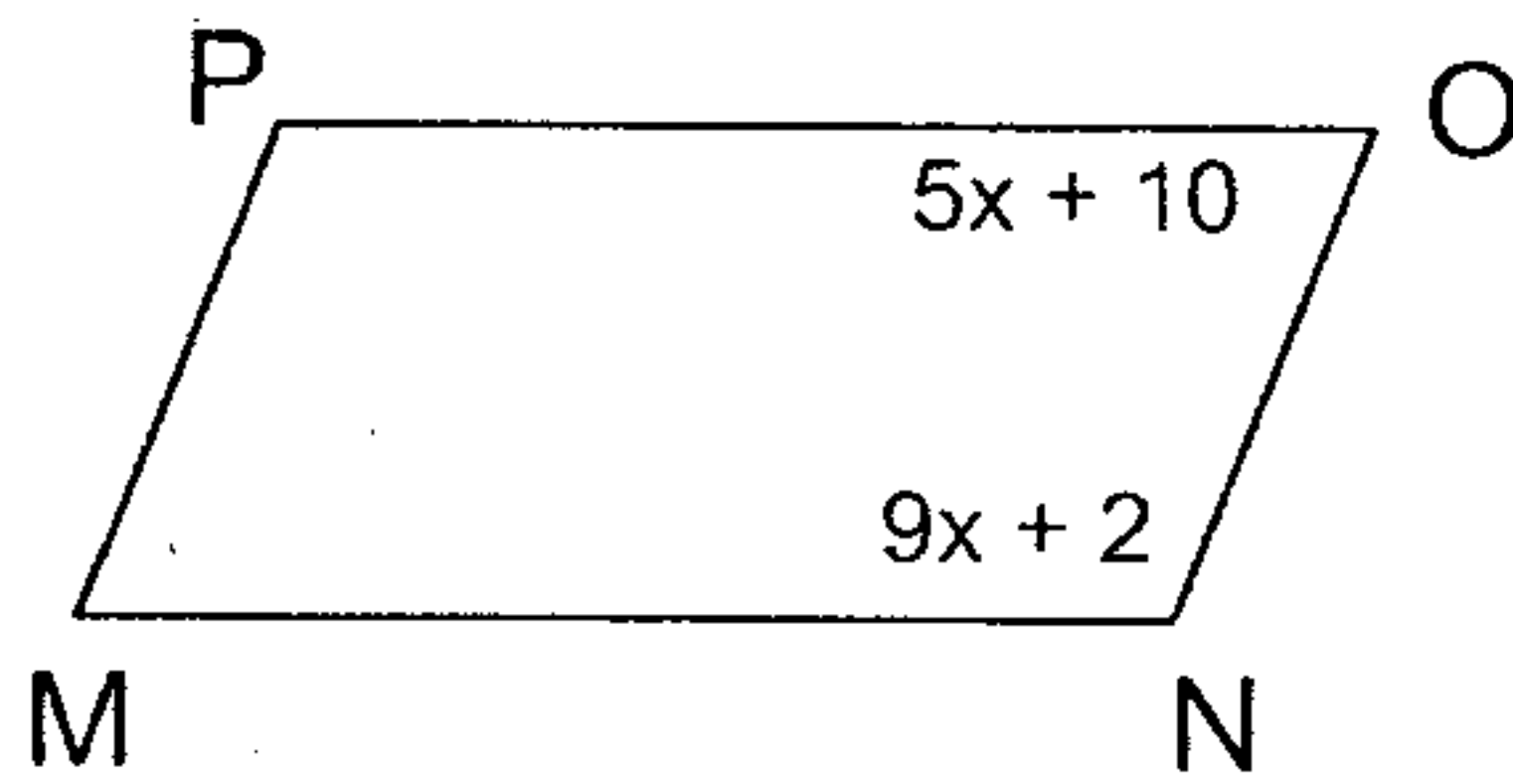

4) In  $\square ABCD$ , if  $AE = x + 3$  and  $CE = 3x - 27$ , then  $x =$

- a. 15
- b. 18
- c. 12
- d. 6

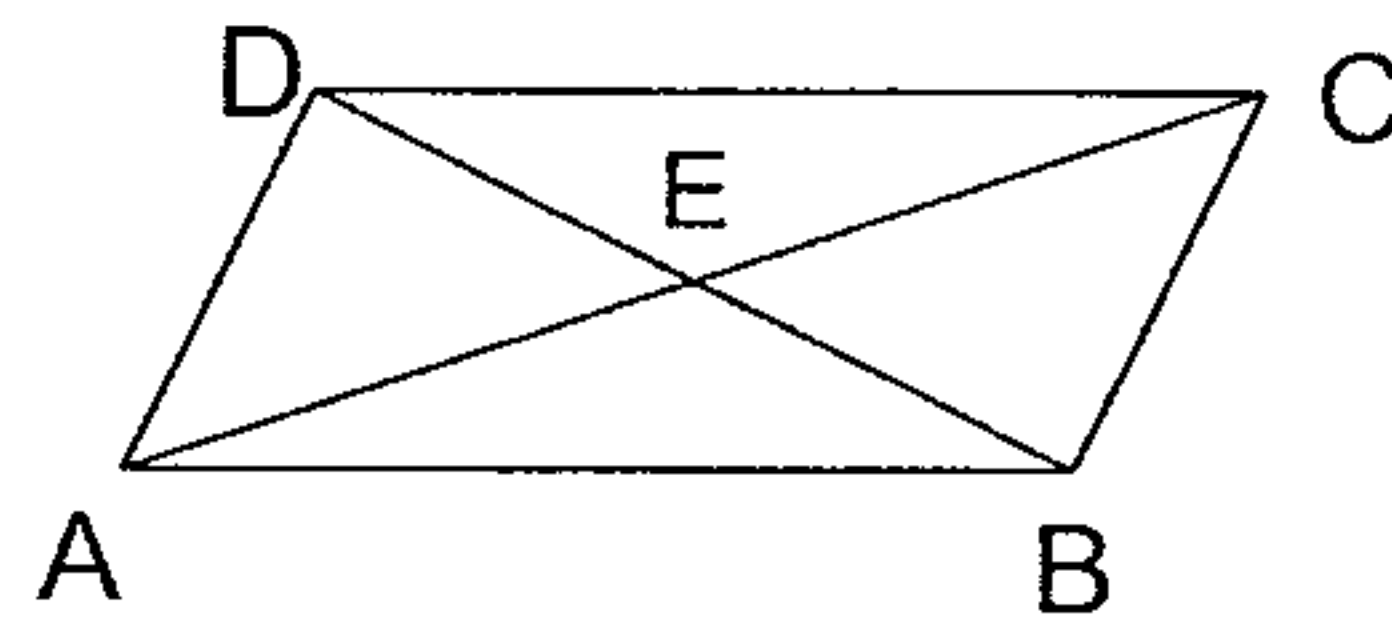

5) If  $\overline{MR} \cong \overline{PR}$ , and \_\_\_\_\_, then  $MNPQ$  is a parallelogram

- a.  $\overline{QP} \cong \overline{MN}$
- b.  $\overline{QP} \parallel \overline{MN}$
- c.  $\overline{QR} \cong \overline{RN}$
- d.  $\overline{MQ} \parallel \overline{NP}$

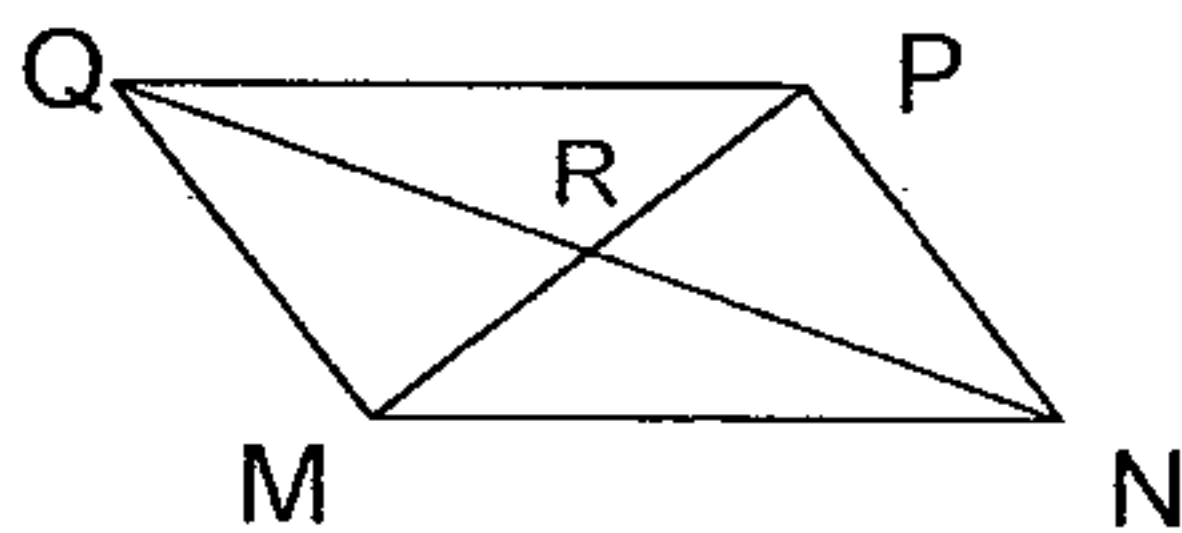

6) State which of the figures are parallelograms.

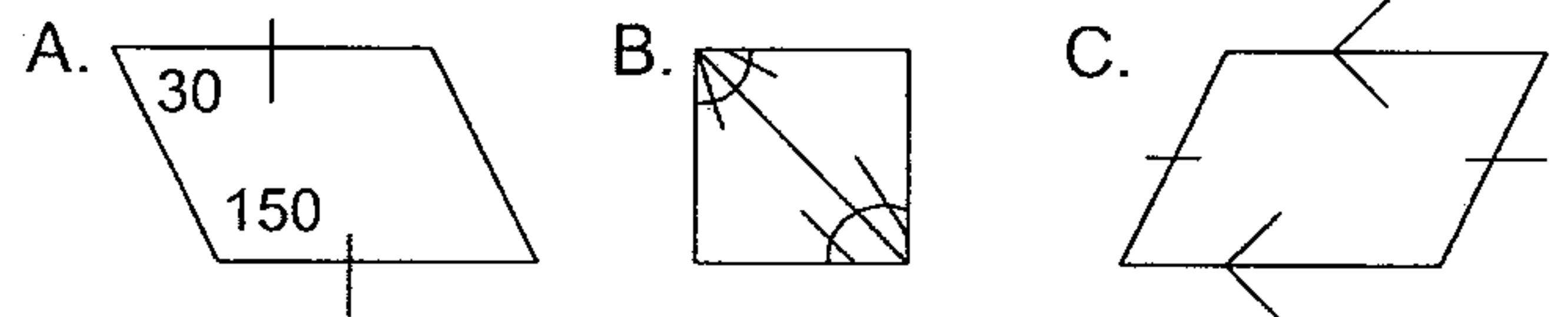

7) Quadrilateral  $ABCD \sim$  Quadrilateral  $EFGH$

- a.  $x =$  \_\_\_\_\_
- b.  $y =$  \_\_\_\_\_
- c.  $z =$  \_\_\_\_\_

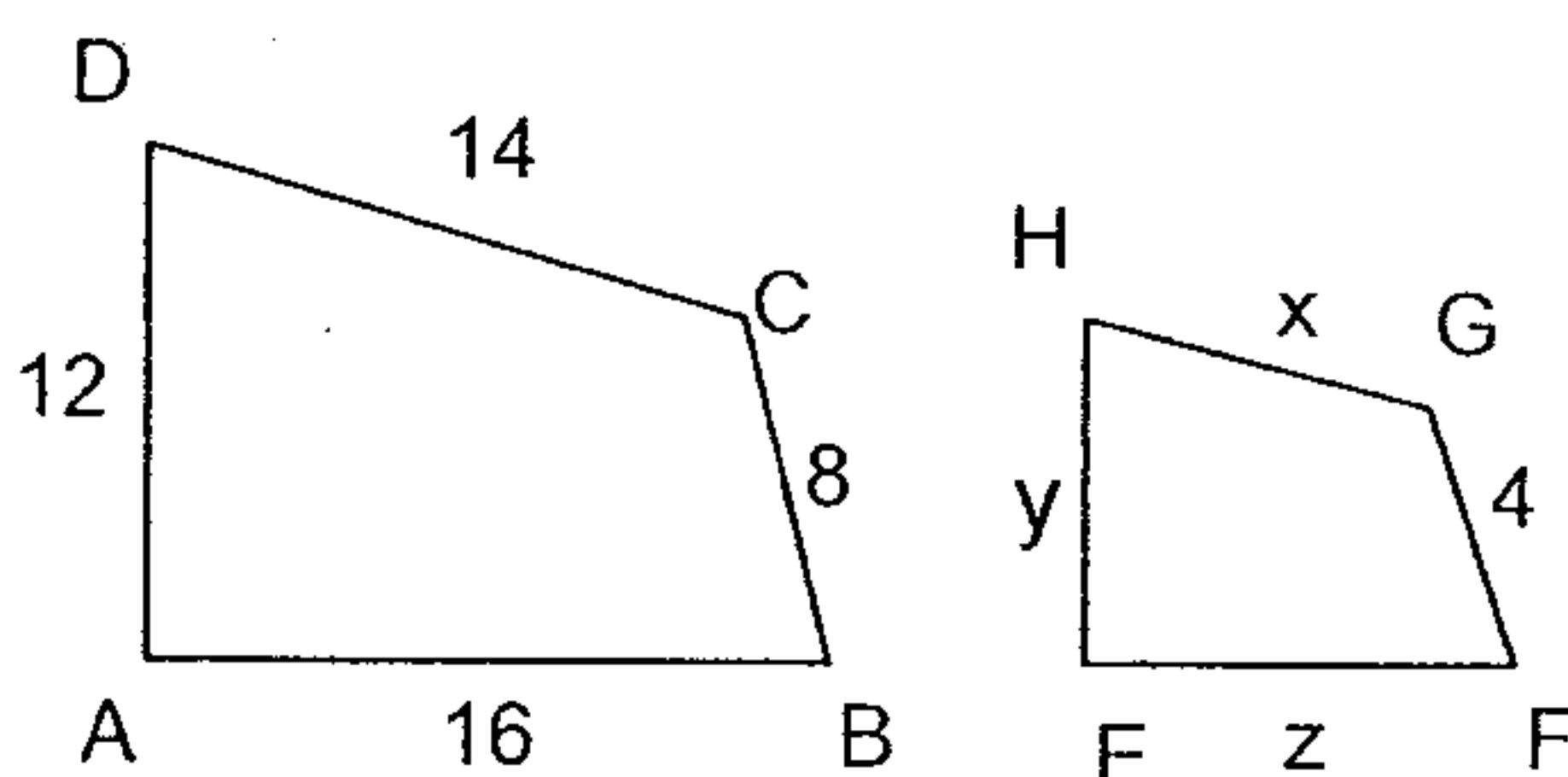

8) The measures of the angles of a quadrilateral are in the ratio of 2:3:5:5. The measure of the smallest of the four angles is \_\_\_\_\_



15) Find  $\tan \angle B$

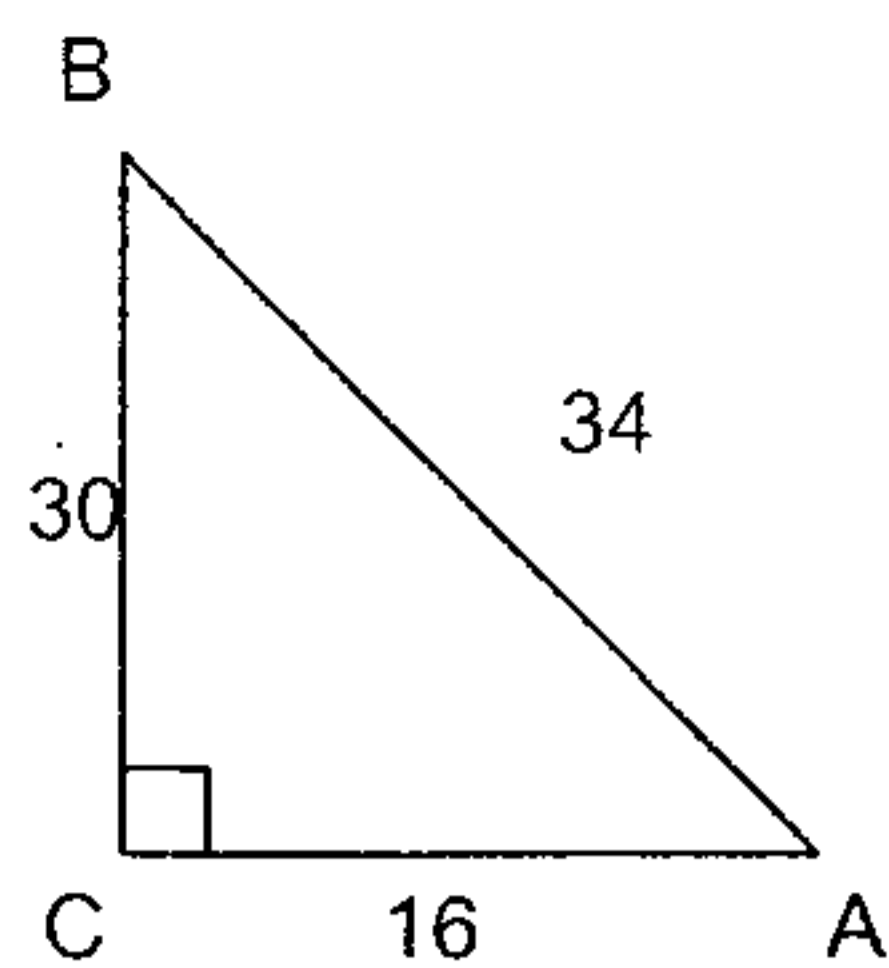

16) Find  $x$ :

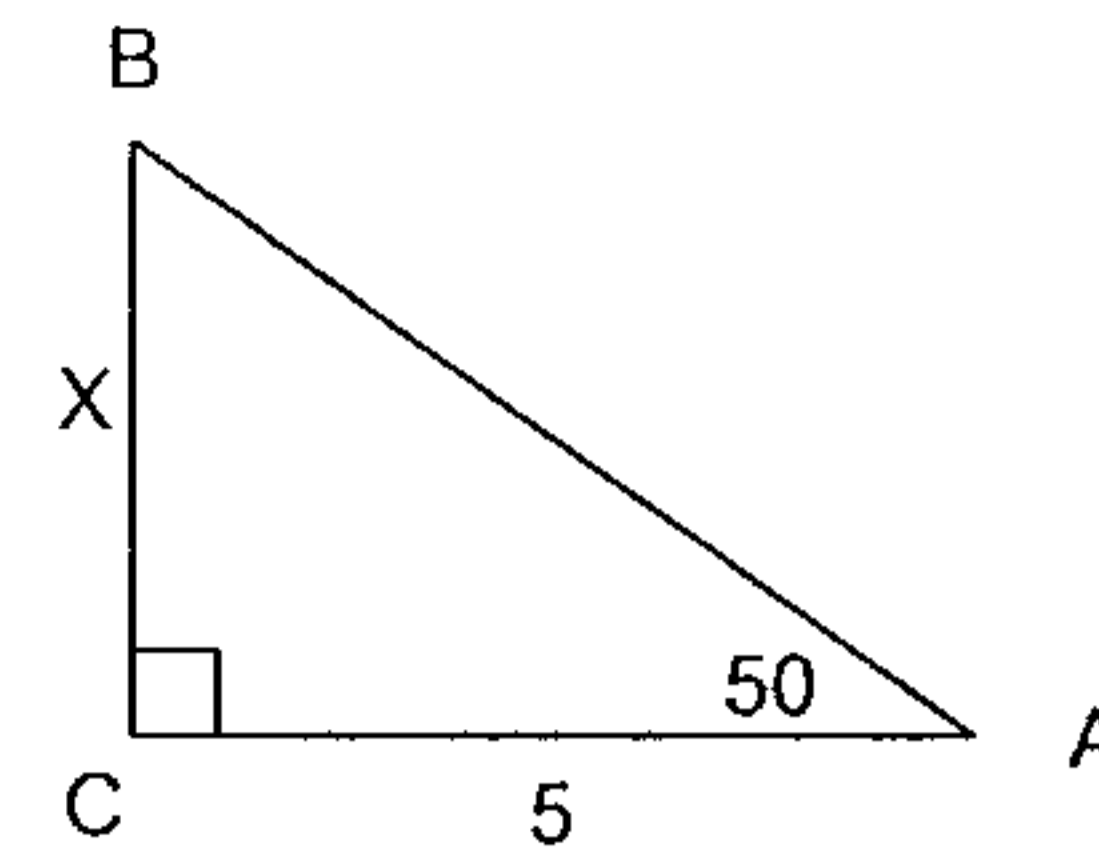

17) Find the altitude of the isosceles trapezoid.

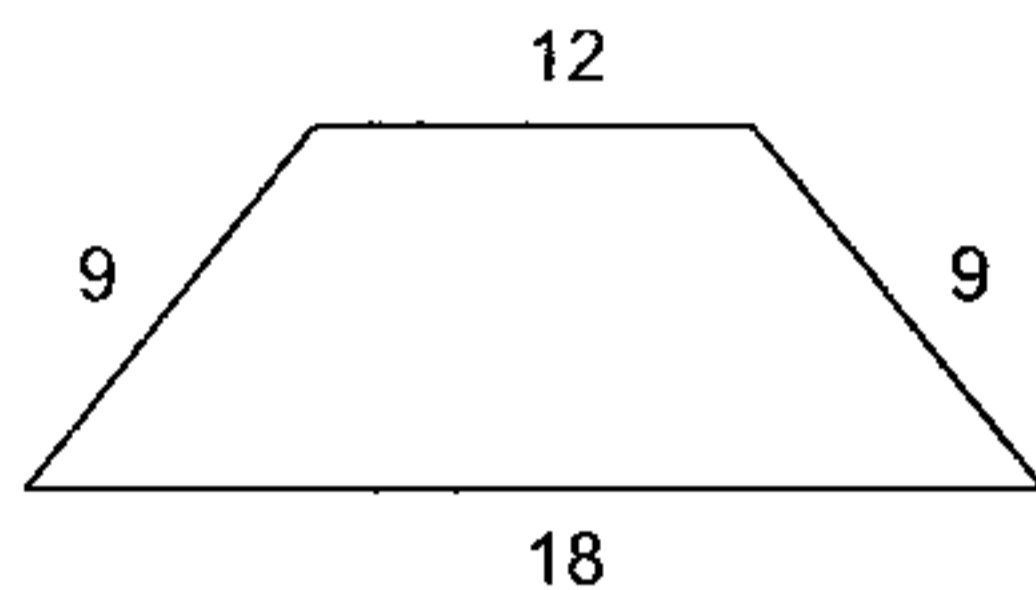

18) Solve for the third side of a right triangle if  $x$  represents a leg and  $r$  represents the hypotenuse.

a.  $x = 15, r = 17$

b.  $x = 5, r = \sqrt{29}$

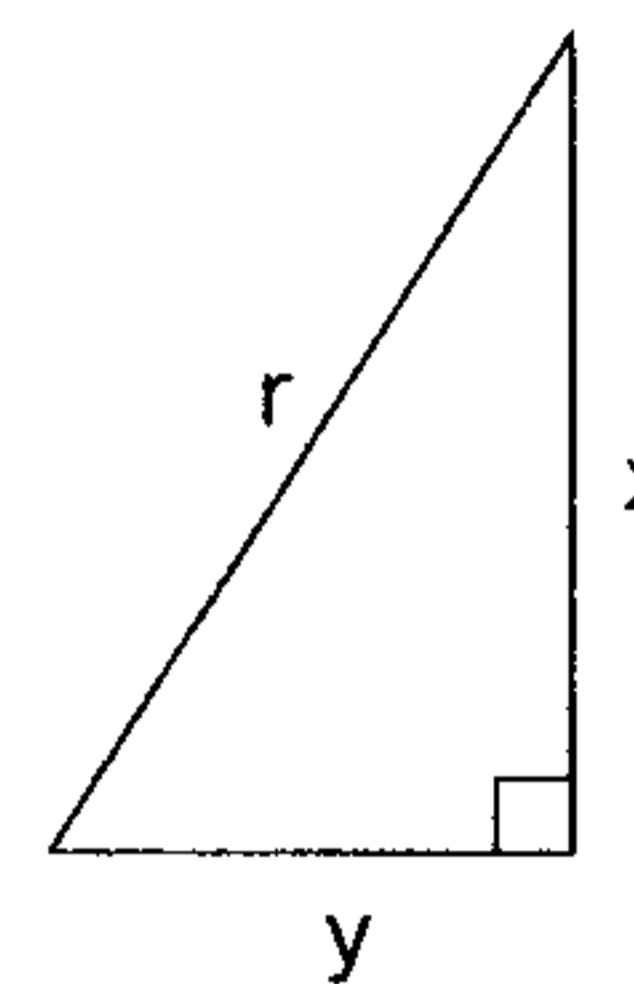

19a) If  $BD = 4$ , Find  $AD$   
 19b) If  $AB = 20$ , find  $CD$

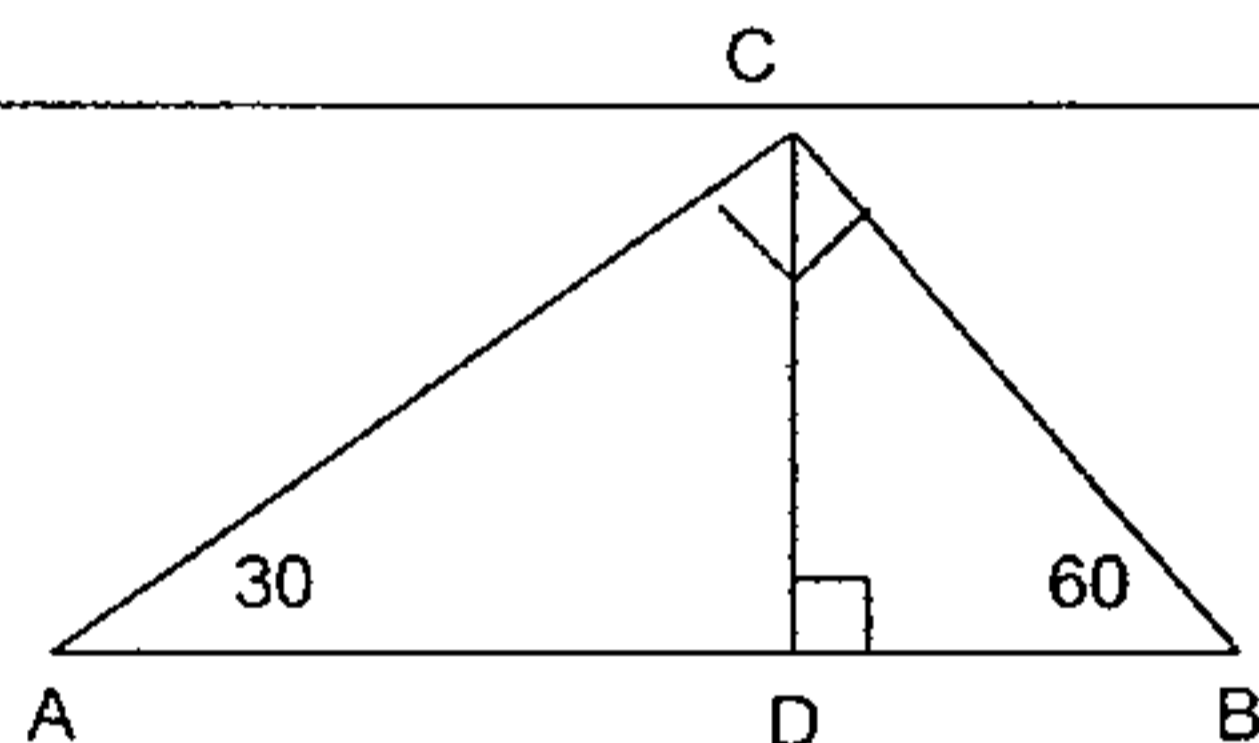

20) Given  $\triangle ABC$  where  $m\angle A = 60$ ,  $m\angle B = 50$ , and  $m\angle C = 70$ , name the sides of the triangle in order from largest to smallest.

21)  $\overline{AC}$  is an altitude of  $\triangle ABD$ ,  $m\angle ACD = x + 84$ ,  $CD = 2x + 3$ ,  $AD = 3x - 1$ ,  $AB = x + 4$ ,  $BC = x$ , find the perimeter of  $\triangle ABD$ .

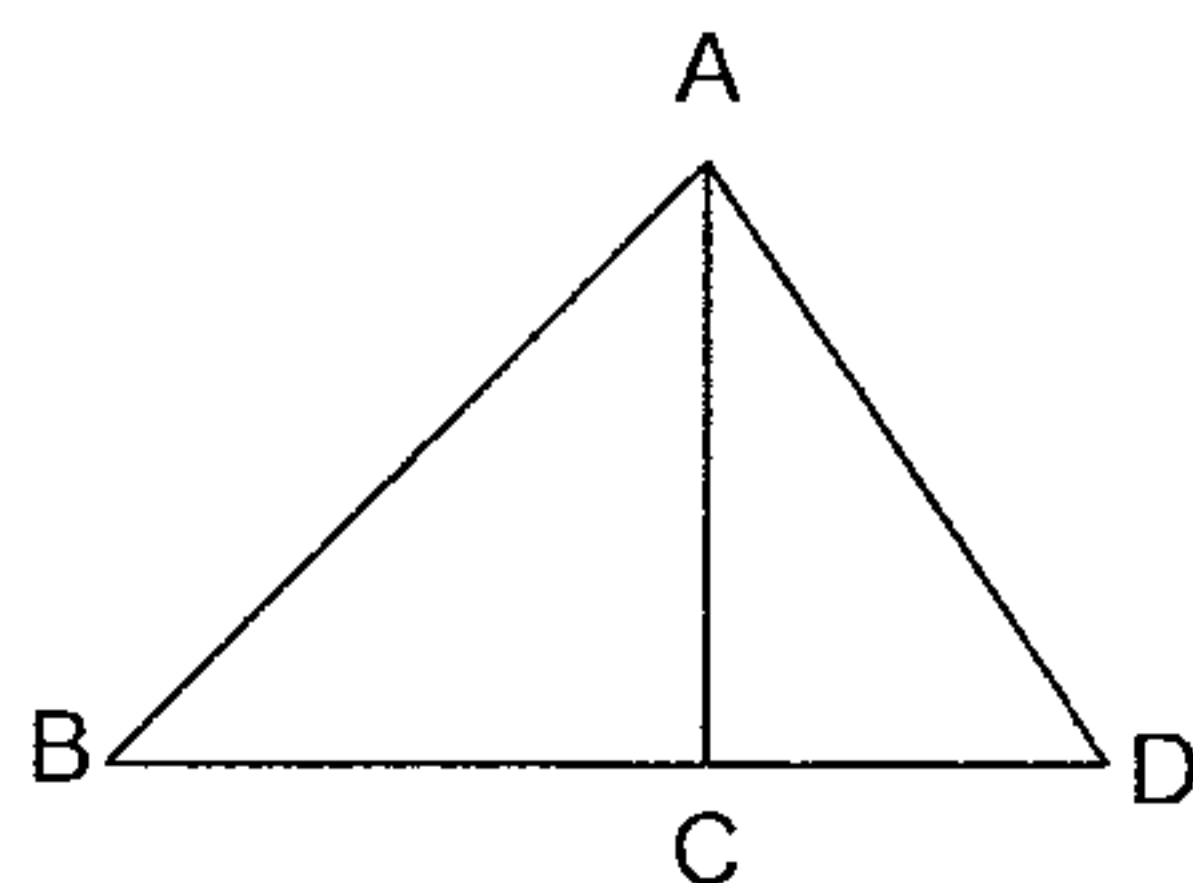

22) Find the area and perimeter of the rectangle.

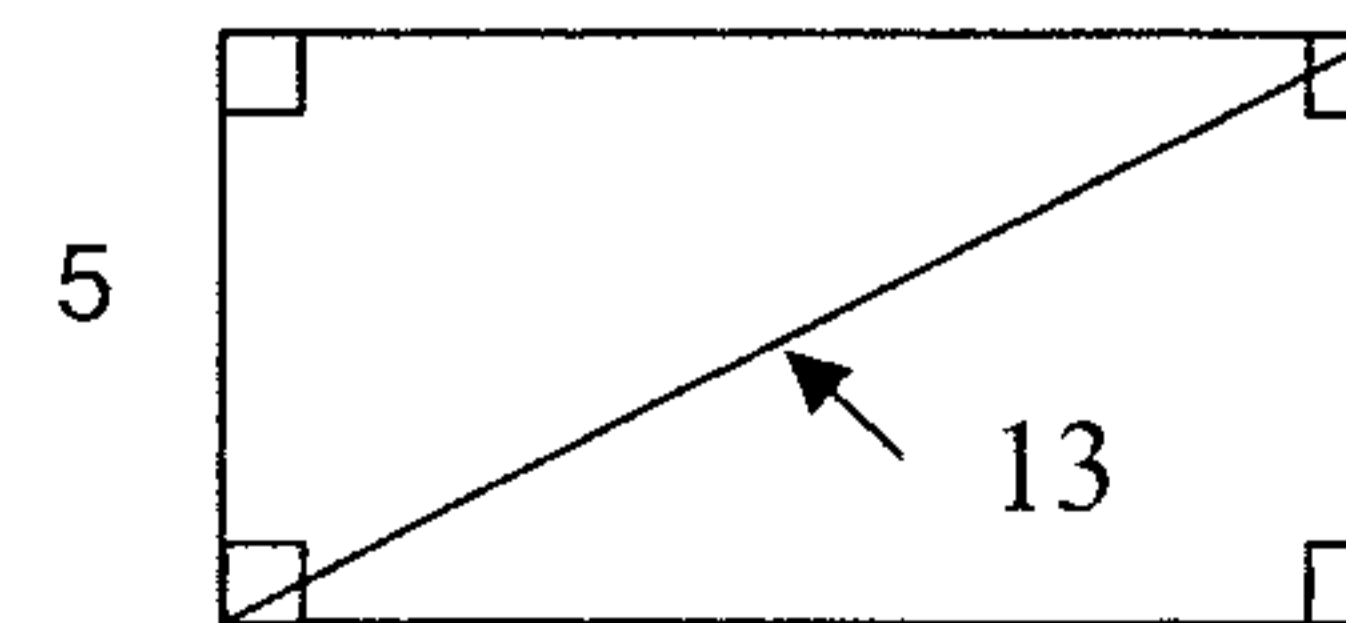

23) Find the length of segment DE.

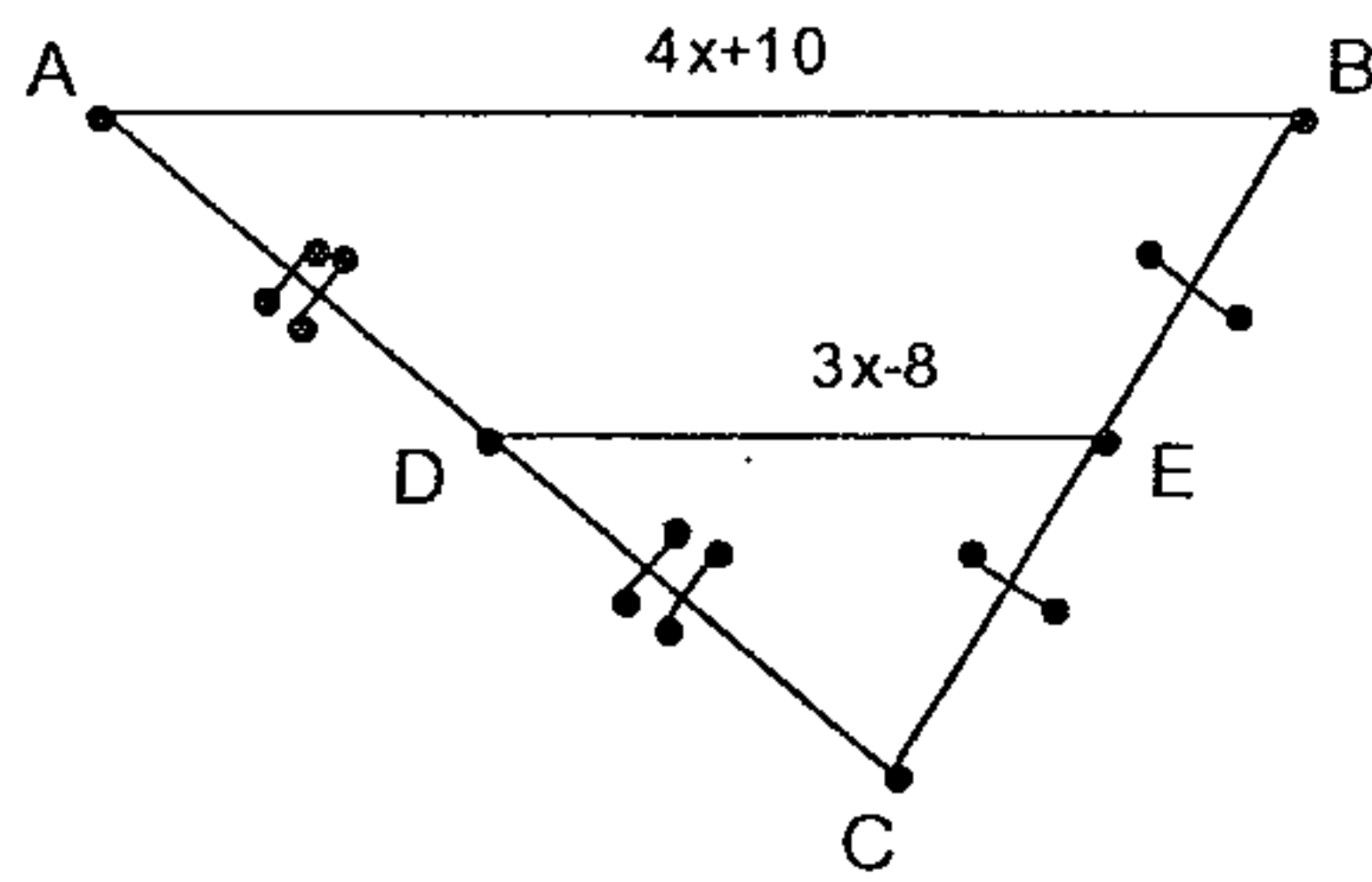

24) Determine if the numbers 3, 3, 4 represent a triangle. If yes, determine if the triangle is right, acute, or obtuse.

25) Find the geometric mean between 36 and 4. \_\_\_\_\_

In the figure,  $\overline{VW} \parallel \overline{RS}$

26a)  $\angle TVW \cong \angle$  \_\_\_\_\_

26b)  $\frac{?}{VR} = \frac{TW}{WS}$

26c) If  $TV = 6$ ,  $VR = 4$ ,  
 $TW = 18$ ,  
 $WS =$  \_\_\_\_\_

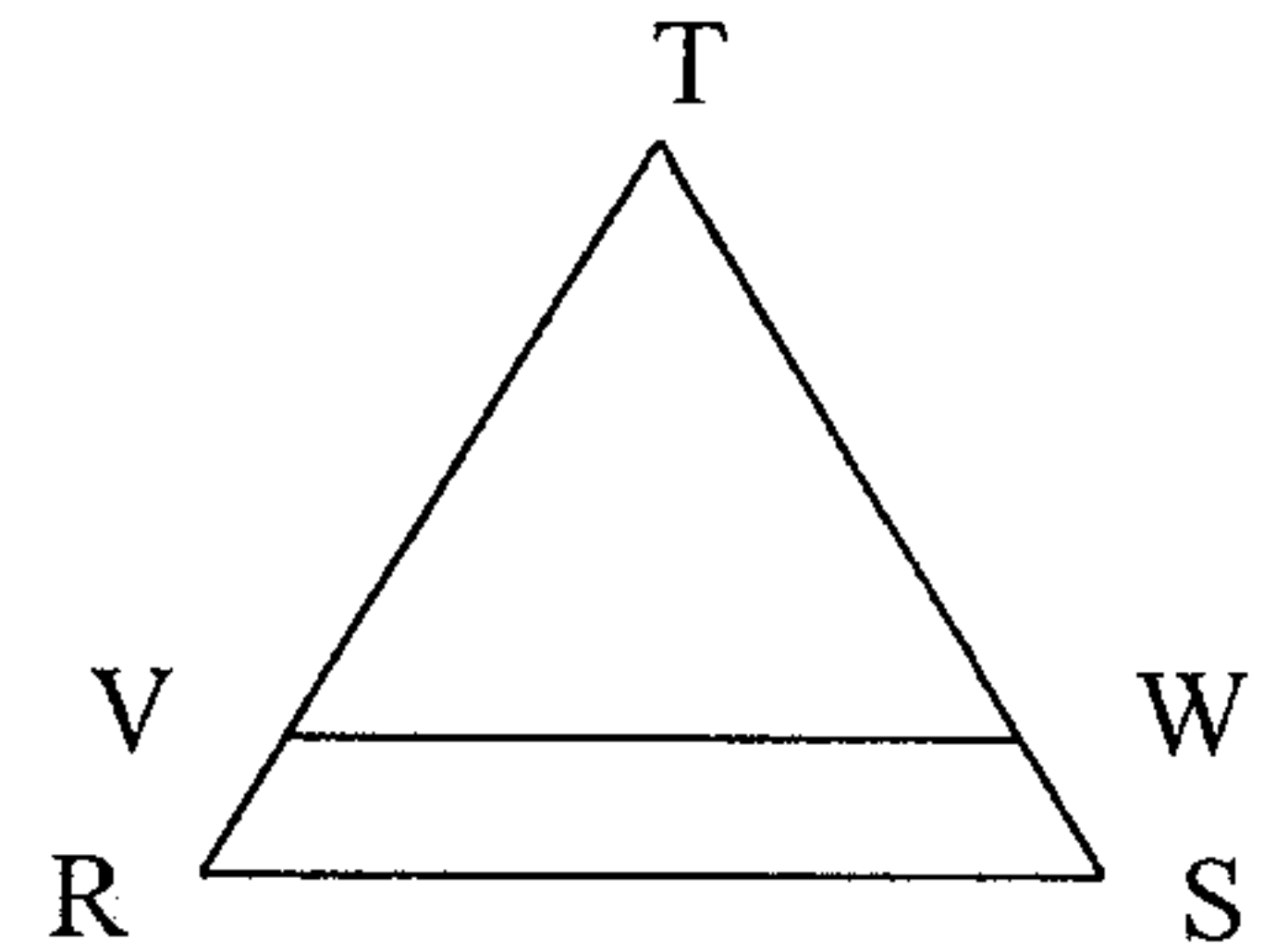

27) Solve the triangle by finding the value of the variables to the nearest tenth

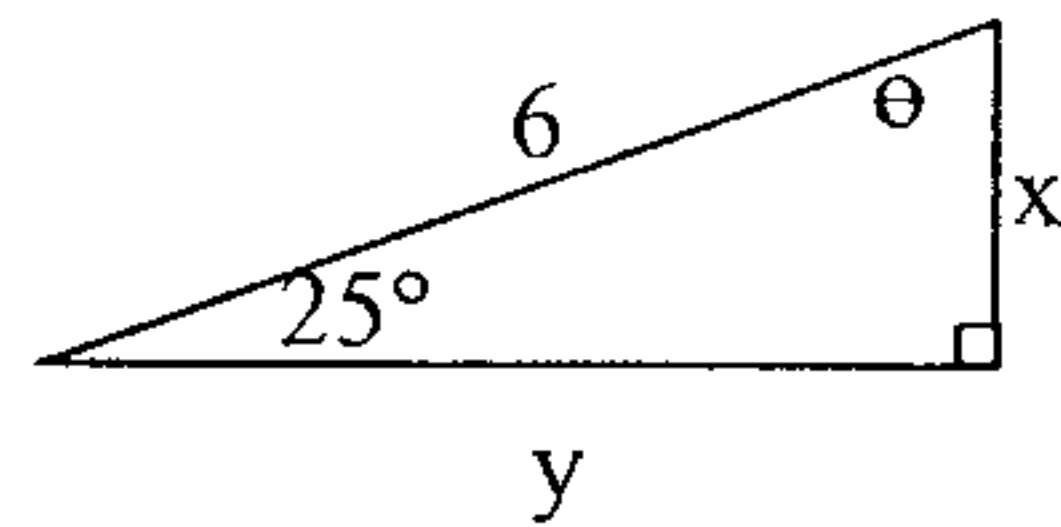

28) Find the value of x. Leave your answer in exact (i.e. radical) form.

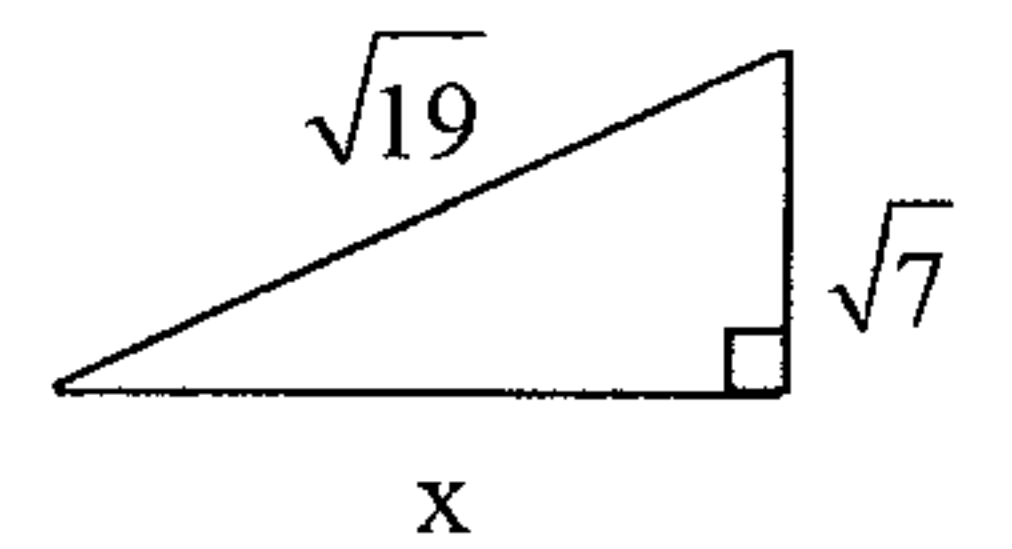

29) Find the value of x and y. Leave your answer in simplified radical form.

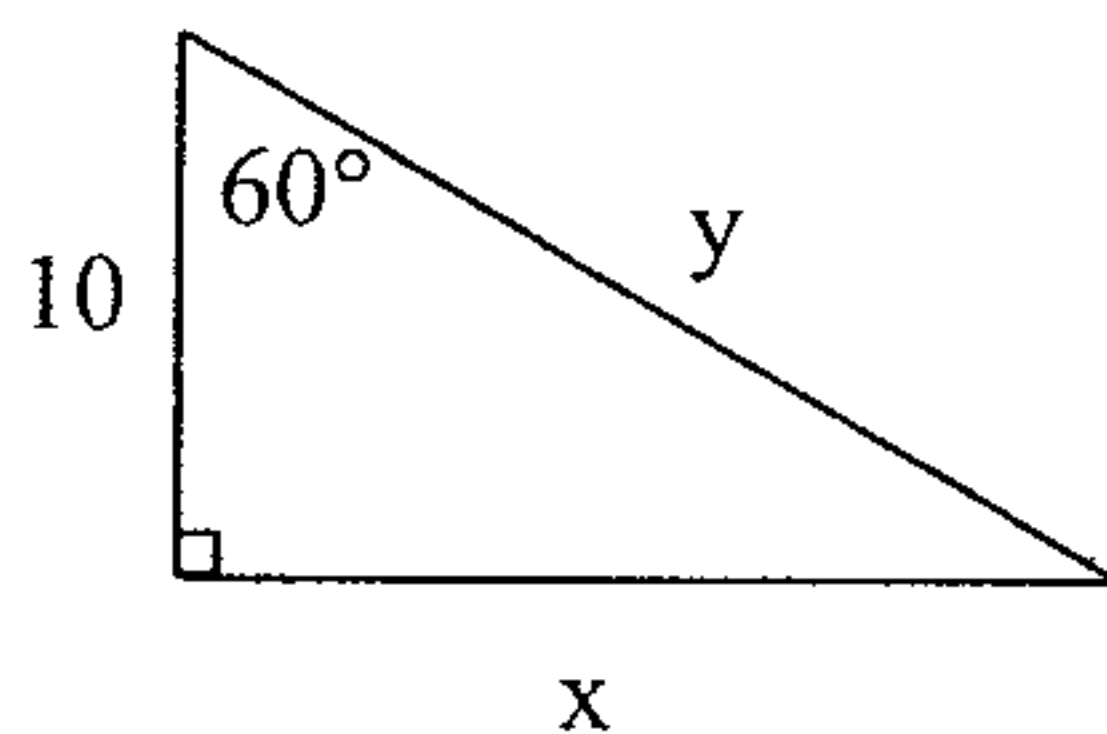

30) The area of a rectangle is 135 square feet. The ratio of the width to the length is 3:5. Find the dimensions. Hint: draw a picture!

Length \_\_\_\_\_

Width \_\_\_\_\_

31) 30°- 60°- 90° triangle

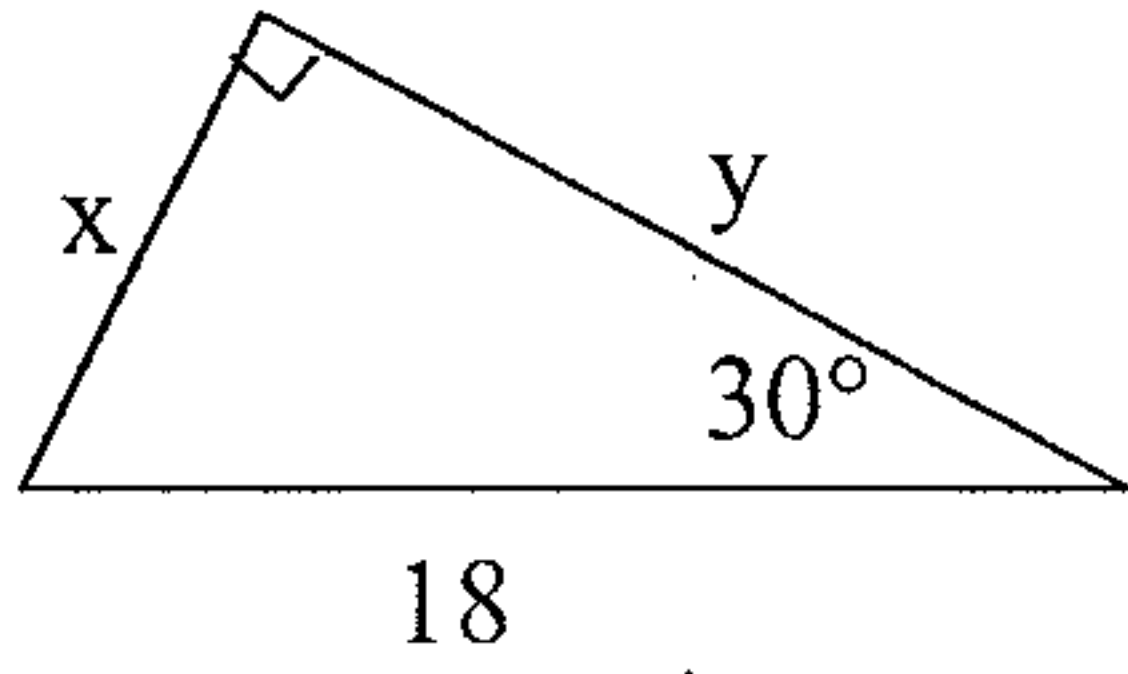

$x = \underline{\hspace{2cm}}$

$y = \underline{\hspace{2cm}}$

32) 45°- 45°- 90° triangle

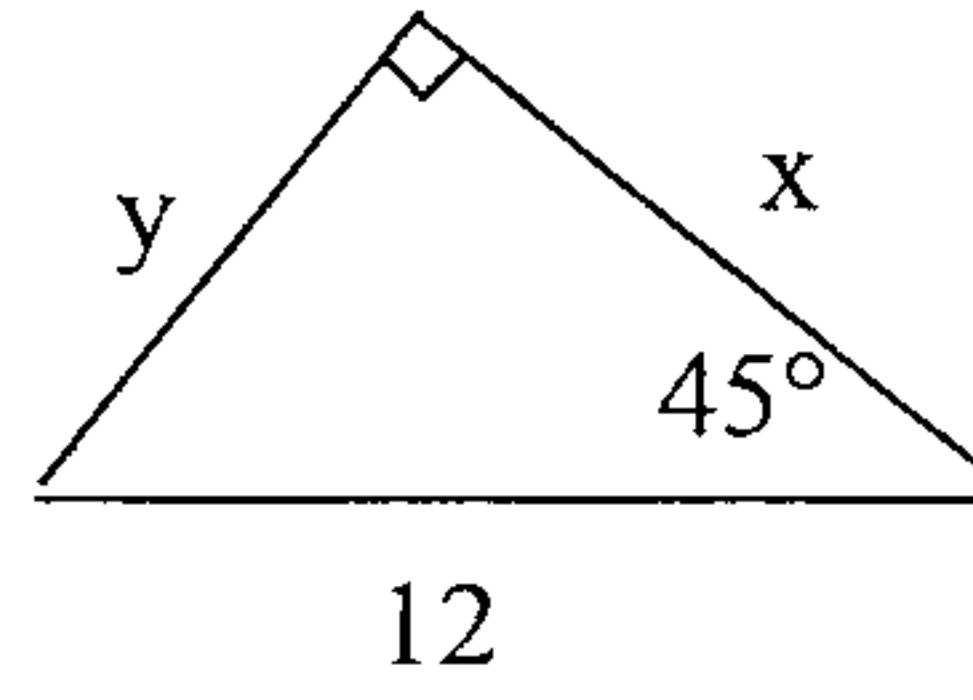

$x = \underline{\hspace{2cm}}$

$y = \underline{\hspace{2cm}}$

33) Find each of the following for  $\odot C$

- a. Area of the circle
- b. Area of the sector
- c. Circumference
- d.  $\widehat{AB}$

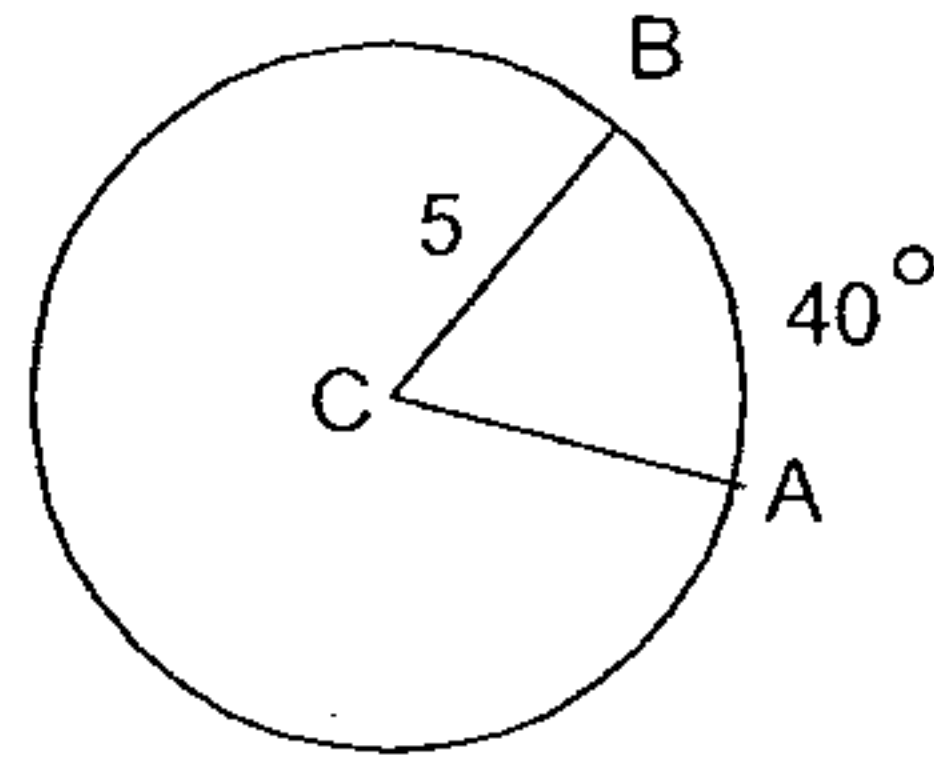

34) A regular hexagon with a perimeter of 24 is inscribed in a circle. How far from the center is each side? i.e. find the apothem.

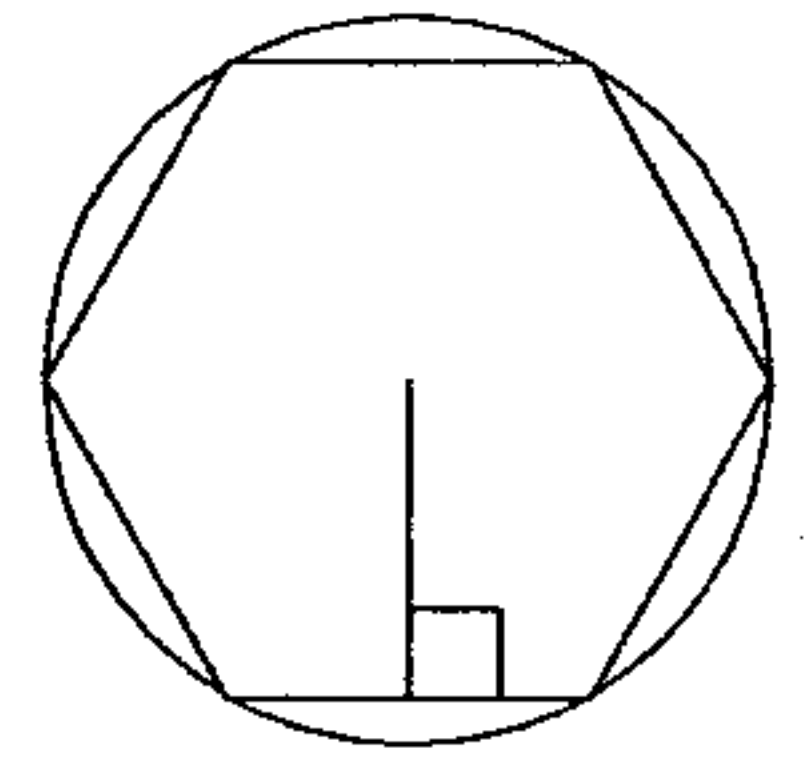

35) Find  $\sin P$ ,  $\cos P$ ,  $\tan P$ :

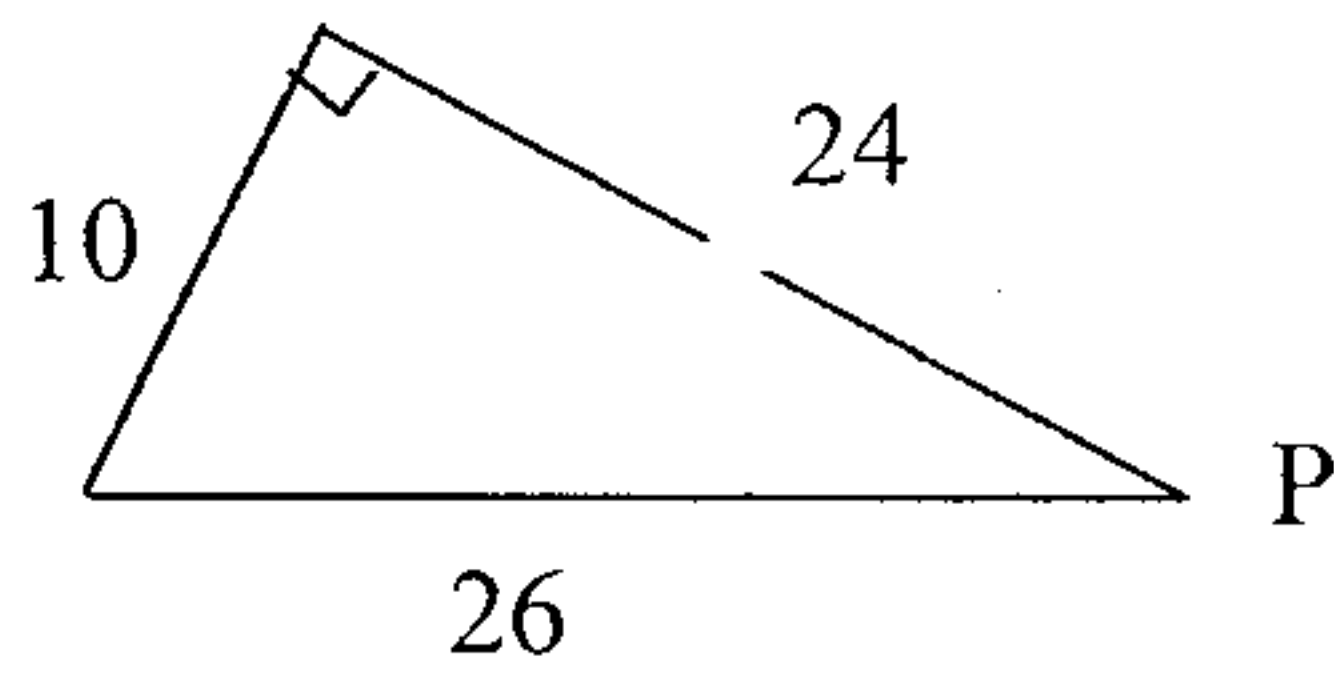

$\sin P = \underline{\hspace{2cm}}$

$\cos P = \underline{\hspace{2cm}}$

$\tan P = \underline{\hspace{2cm}}$

36) Solve the right triangle. Round decimals to the nearest tenth.

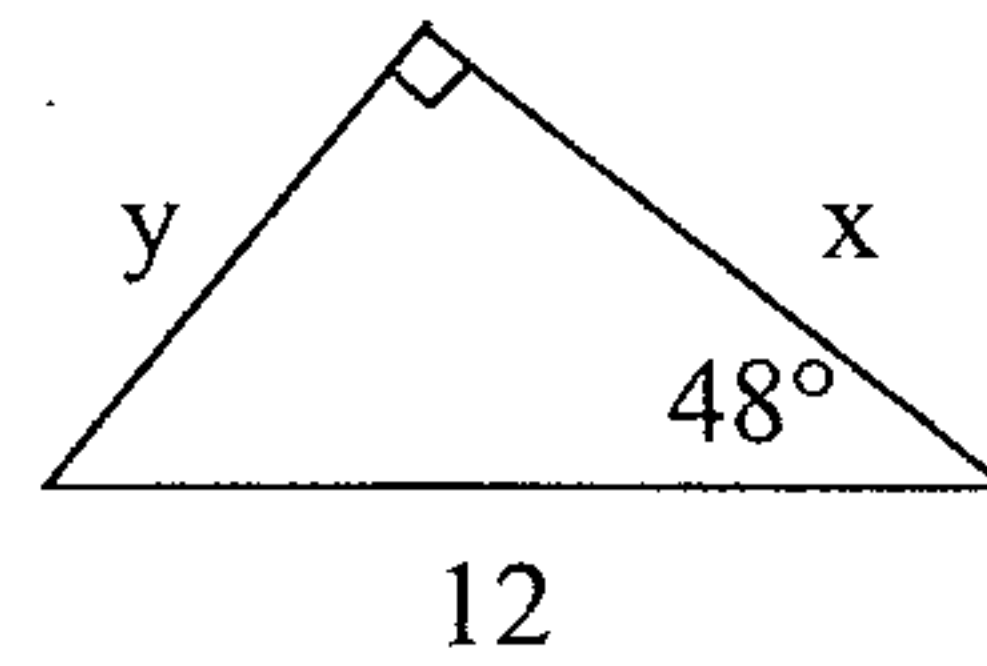

$x = \underline{\hspace{2cm}}$

$y = \underline{\hspace{2cm}}$

angle =  $\underline{\hspace{2cm}}$

37) Use parallelogram ABCD on the right to answer the following questions.

- a.  $\overline{AD} \cong \underline{\hspace{2cm}}$
- b.  $\overline{EB} \cong \underline{\hspace{2cm}}$
- c.  $\angle ADC \cong \underline{\hspace{2cm}}$
- d.  $\angle ABD \cong \underline{\hspace{2cm}}$
- e.  $\angle BAC \cong \underline{\hspace{2cm}}$
- f.  $\angle DAC \cong \underline{\hspace{2cm}}$

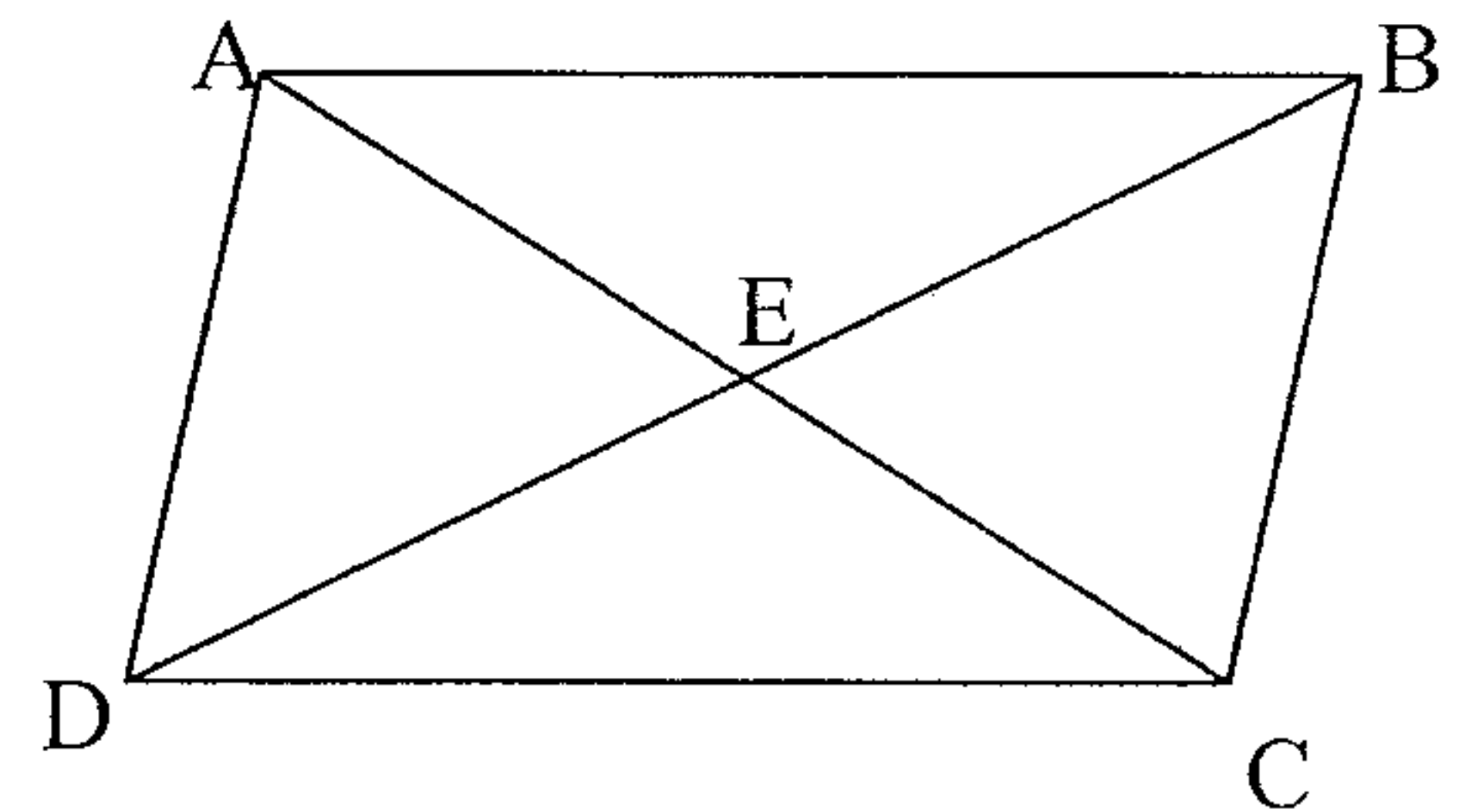

38a) If  $m\angle BAC=60^\circ$  and  $m\angle CAD=48^\circ$ , then

$m\angle BCD=$  \_\_\_\_\_  $m\angle ADC=$  \_\_\_\_\_

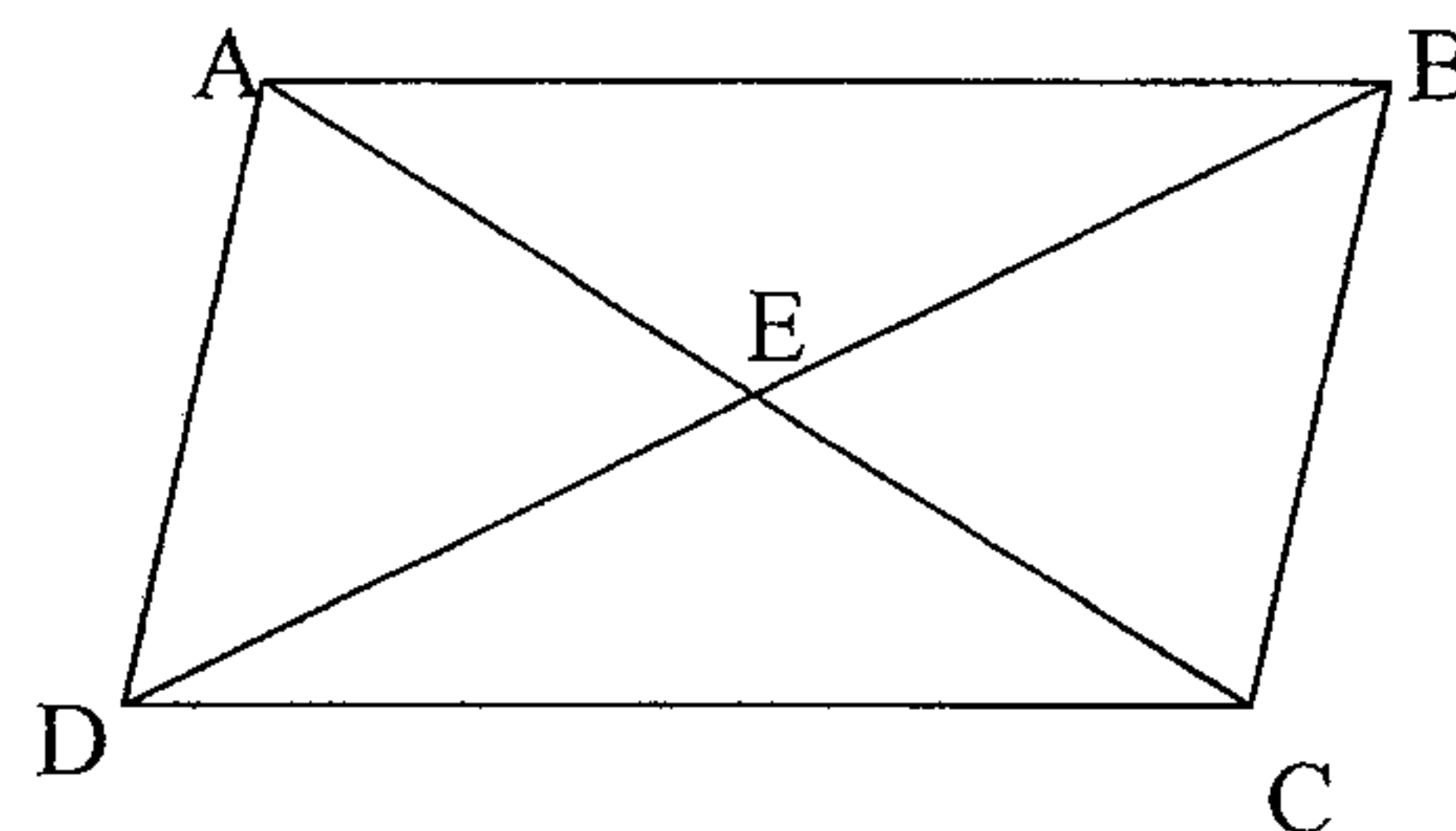

38b) If  $m\angle BCD=3x$  and  $m\angle ABC=2x-10$ , find  $m\angle ABC$ . \_\_\_\_\_

38c) If  $\overline{DE}=4x+5$  and  $\overline{EB}=5x-14$ , find  $\overline{DB}$ . \_\_\_\_\_

39) List the definition and properties you learned about the following quadrilaterals and the circle. List the formulas for the area and perimeter/circumference for each one. Write out an example problem for each.

**Parallelogram:**

Definition –

Properties –

Area of parallelogram –

Example problem using area –

**Kite :**

Definition –

Properties -

Area of kite –

Example problem using area –

**Rhombus:**

Definition –

Properties -

Area of rhombus –

Example problem using area –

**Rectangle:**

Definition –

Properties -

Area of rectangle –

Example problem using area –

**Triangle:**

Definition –

Properties -

Area of triangle –

Example problem using area –

**Trapezoid:**

Definition –

Properties -

Area of trapezoid –

Example problem using area –

**Isosceles Trapezoid:**

Definition –

Properties -

Area of isosceles trapezoid –

Example problem using area –

**Circle:**

Definition –

Properties -

Area of circle –

Example problem using area –

40) Write the equation to find the surface area and volume of a **cylinder**. Draw a cylinder and list the variables that relate to the cylinder. Use a height of 6 inches and a radius of 9.5 inches to calculate the surface area and volume.

S.A. = \_\_\_\_\_

Vol. = \_\_\_\_\_

41) Write the equation to find the surface area and volume of a **rectangular prism**. Draw a rectangular prism and list the variables that relate to the rectangular prism. Use a height of 16 cm, a length of 9 cm and a width of 4 cm to calculate the surface area and volume.

S.A. = \_\_\_\_\_

Vol. = \_\_\_\_\_

42) Write the equation to find the surface area and volume of a **cone**. Draw a cone and list the variables that relate to the cone. Use a base radius of 6 cm, and a slant height of 10 cm to calculate the surface area and volume.

S.A. = \_\_\_\_\_

Vol. = \_\_\_\_\_

43) Write the equation to find the surface area and volume of a **pyramid**. Draw a pyramid and list the variables that relate to the pyramid. Use a square base where sides are 10 inches, and the height or altitude is 12 inches to calculate the surface area and volume.

S.A. = \_\_\_\_\_

Vol. = \_\_\_\_\_

44) Write the equation to find the surface area and volume of a **sphere**. Draw a sphere and list the variables that relate to the sphere. Use a radius of 7 inches to calculate the surface area and volume.

S.A. = \_\_\_\_\_

Vol. = \_\_\_\_\_

45) Find the value of  $x$ .

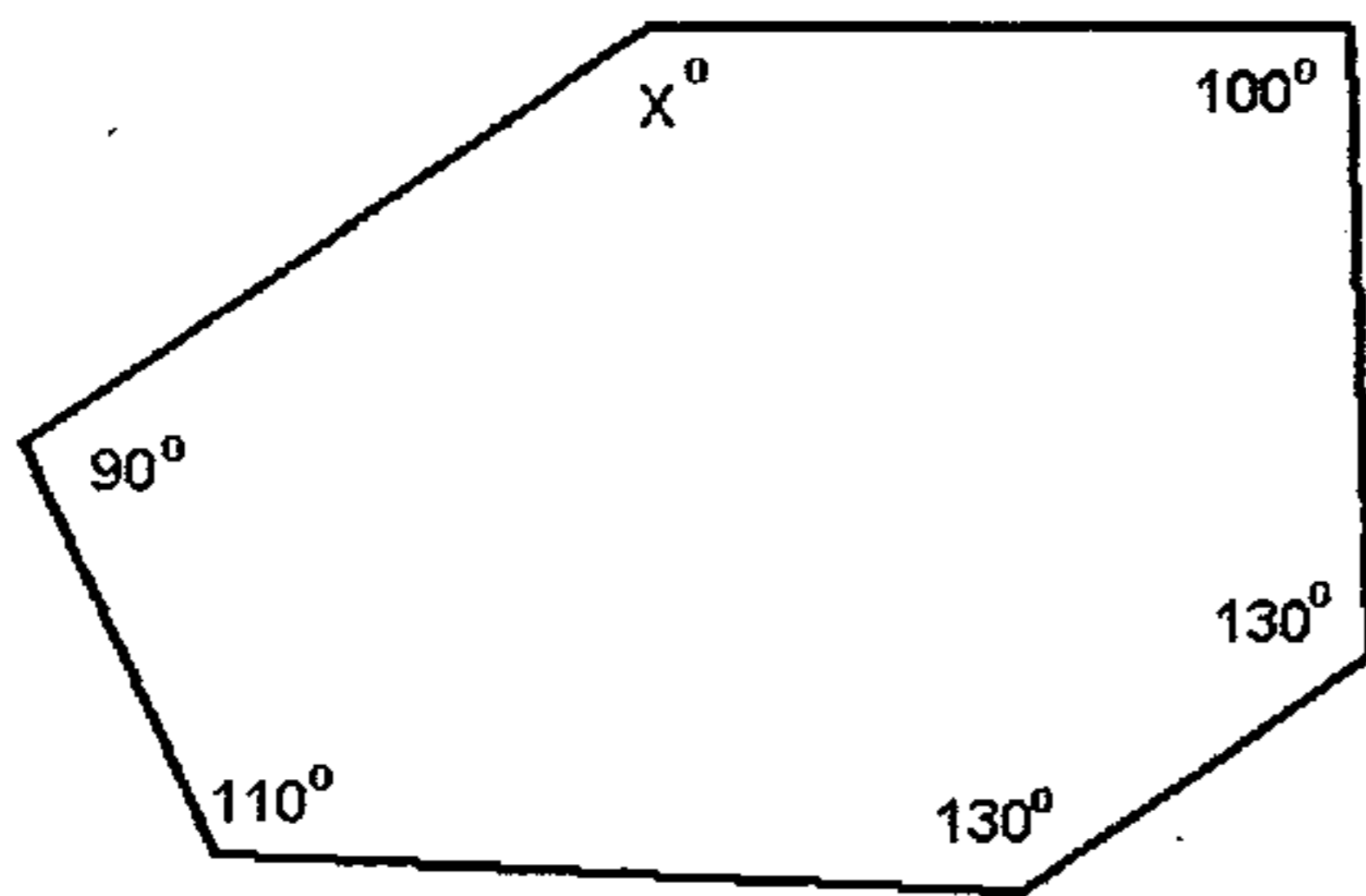

46) Find the value of  $x$ . The sum of the exterior angles in a polygon = \_\_\_\_\_.

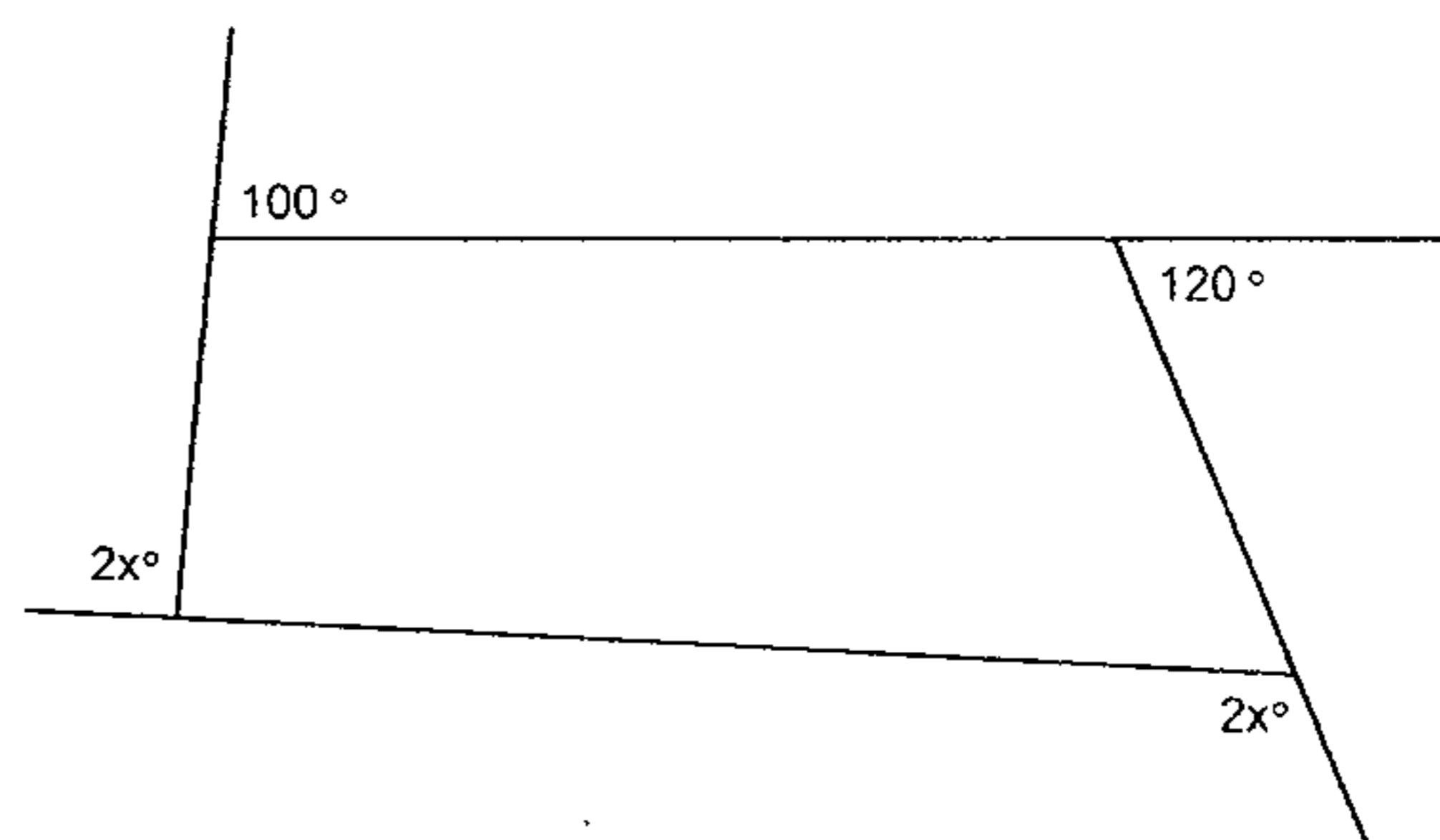

47) Find the area of the kite.

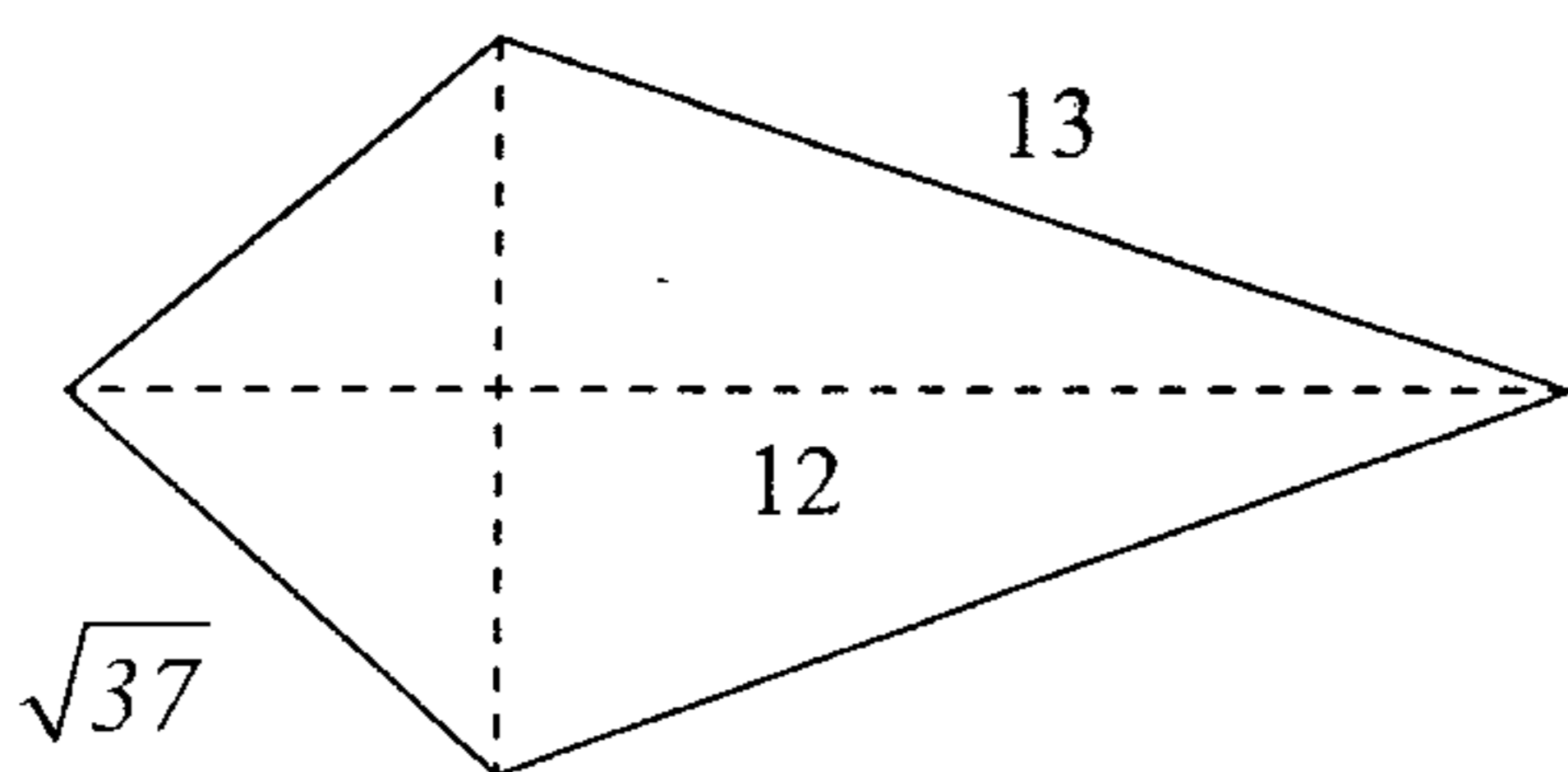

48) Find the area of the trapezoid.  
Find the midsegment.

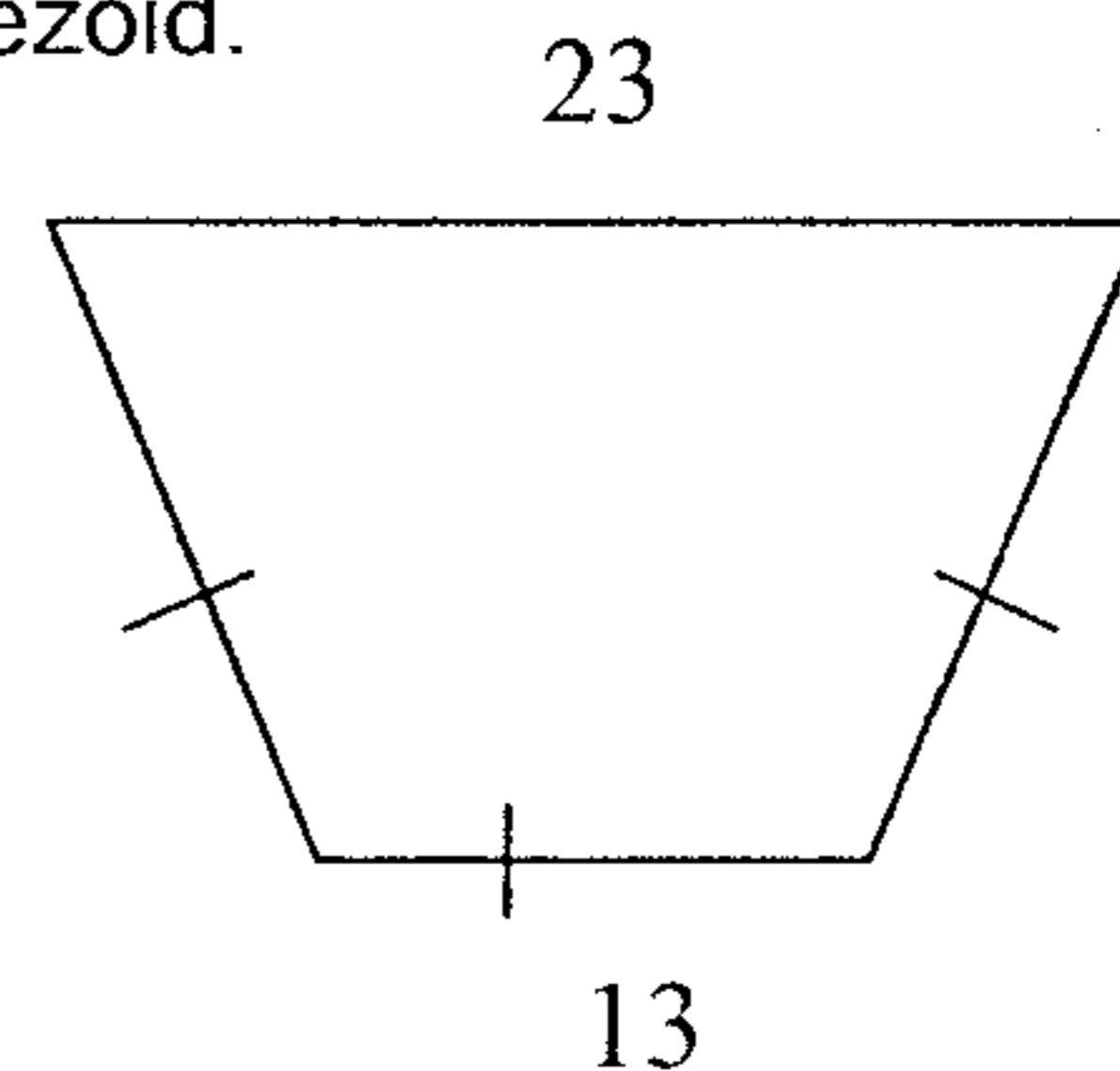

49) Find the area of the trapezoid.

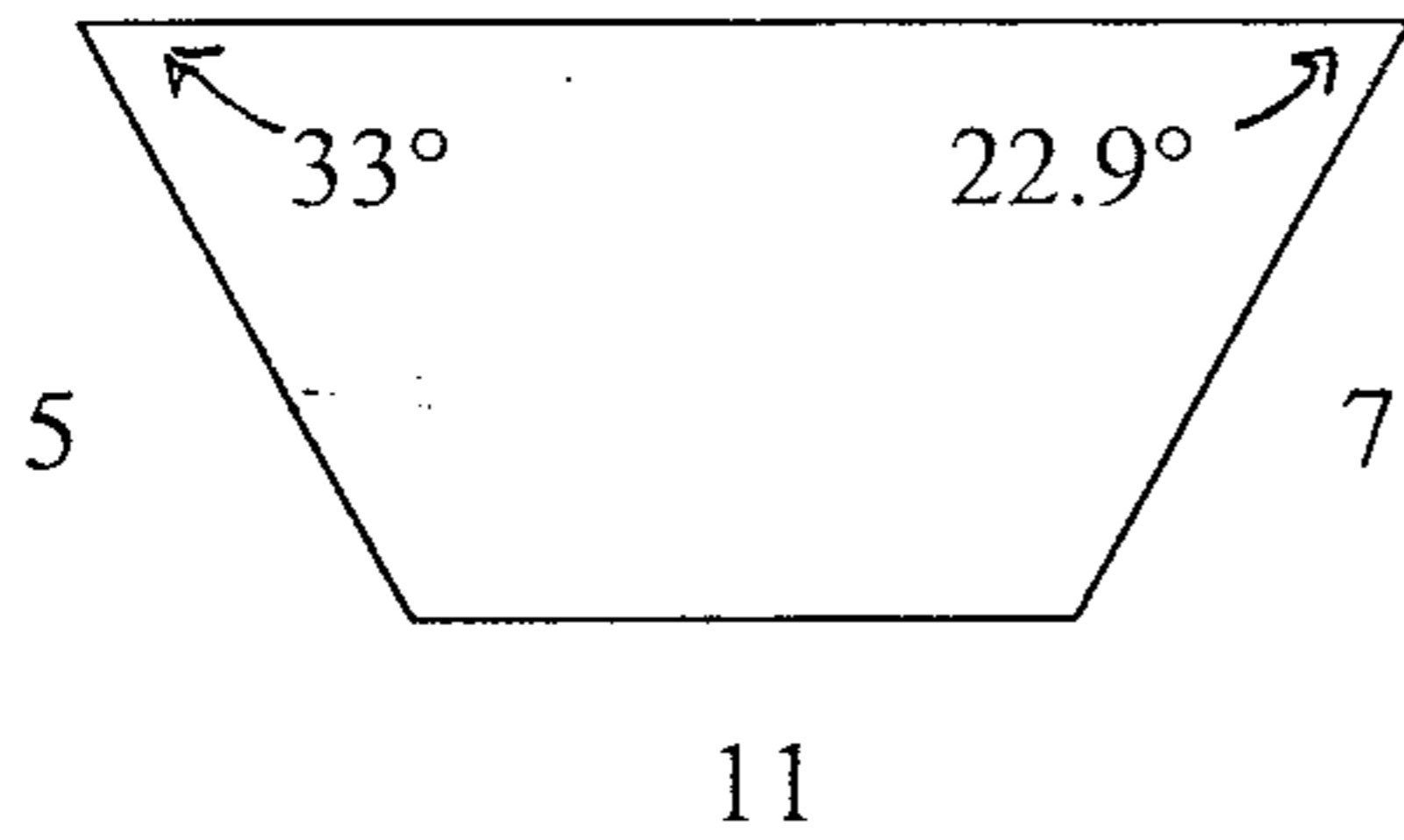

50) Determine if the triangles are similar. If so, what theorem or postulate tells you so?

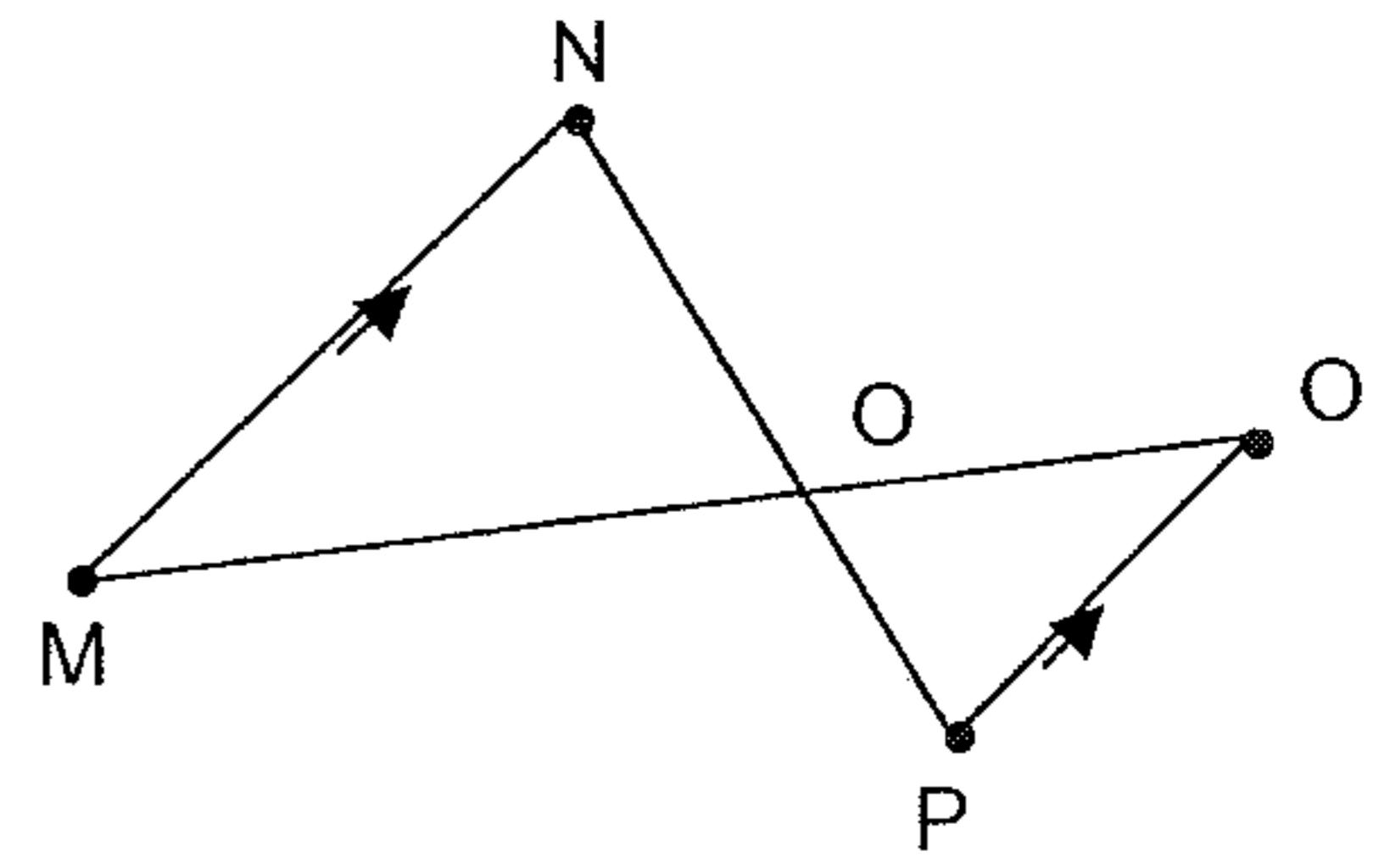

51) Find the values of  $x$  and  $y$ .

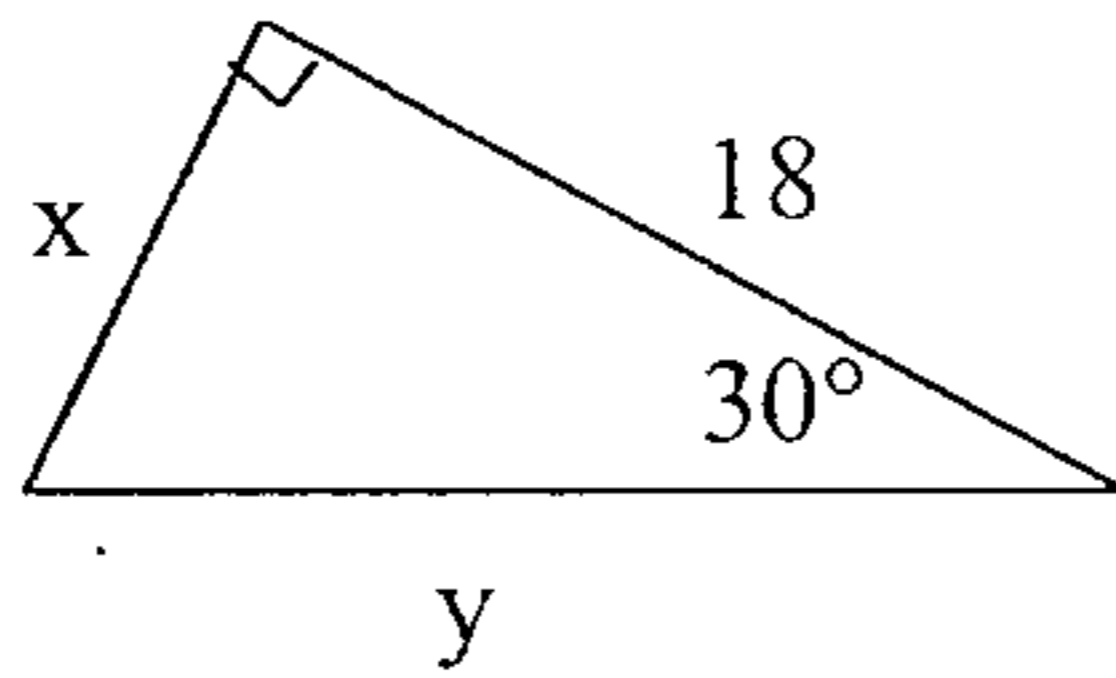

52) Find the values of  $x$  and  $y$ .

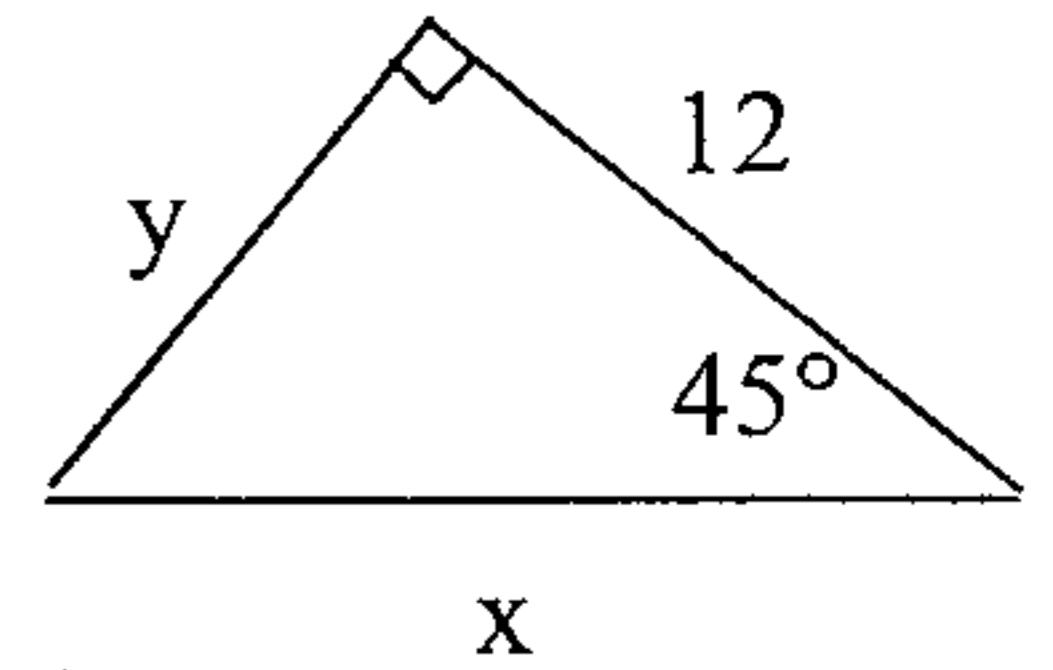

53) A kite is held by a taut string pegged to the ground. The string is 40 feet long and makes a  $33^\circ$  angle with the ground. Supposing that the ground is level, find the vertical distance from the ground to the kite.

54) A rectangle has a width of 30 centimeters. The diagonal makes an angle of  $36^\circ$  with the length. Find the length of the diagonal.

55) A 6 foot man casts a 4 foot shadow at the same time a monument casts a 24 foot shadow. How high is the monument?

56) Which theorem or postulate can be used to show that the triangles below are similar? Find  $x$  and  $y$ .

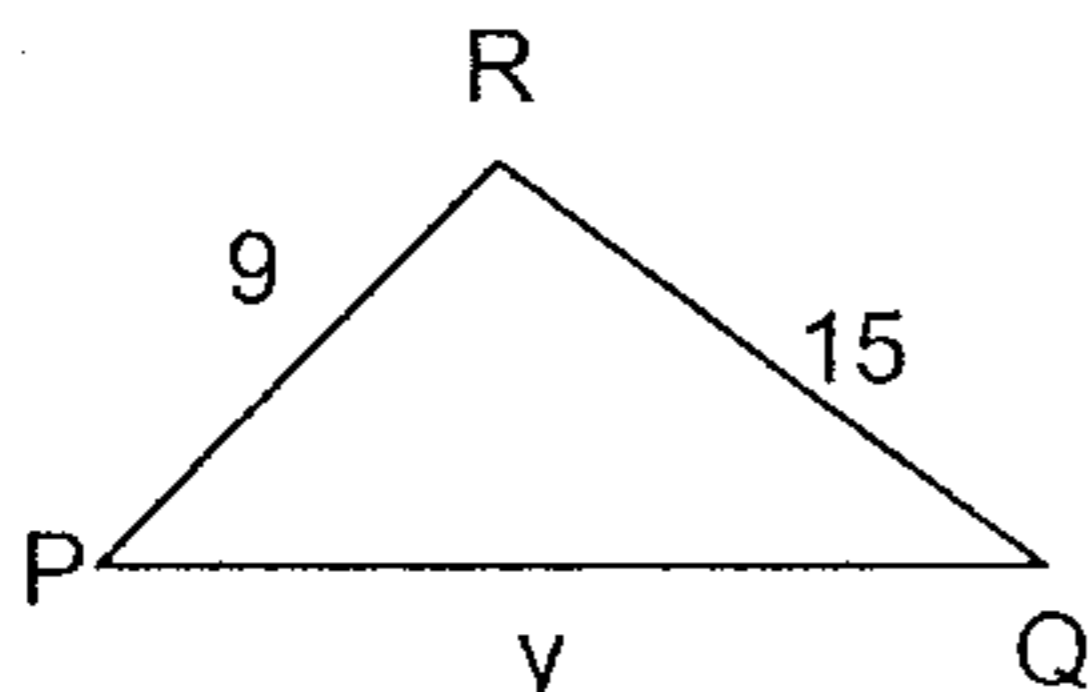
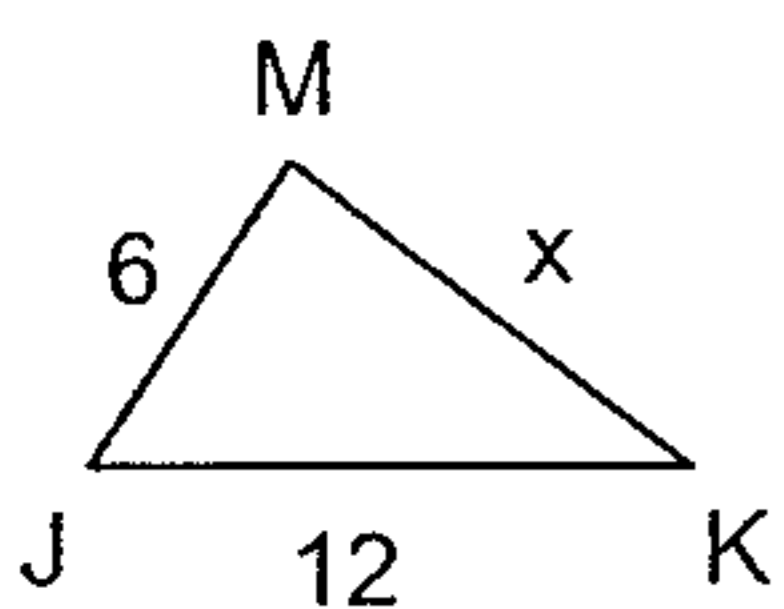

57) Find the missing lengths.

a.

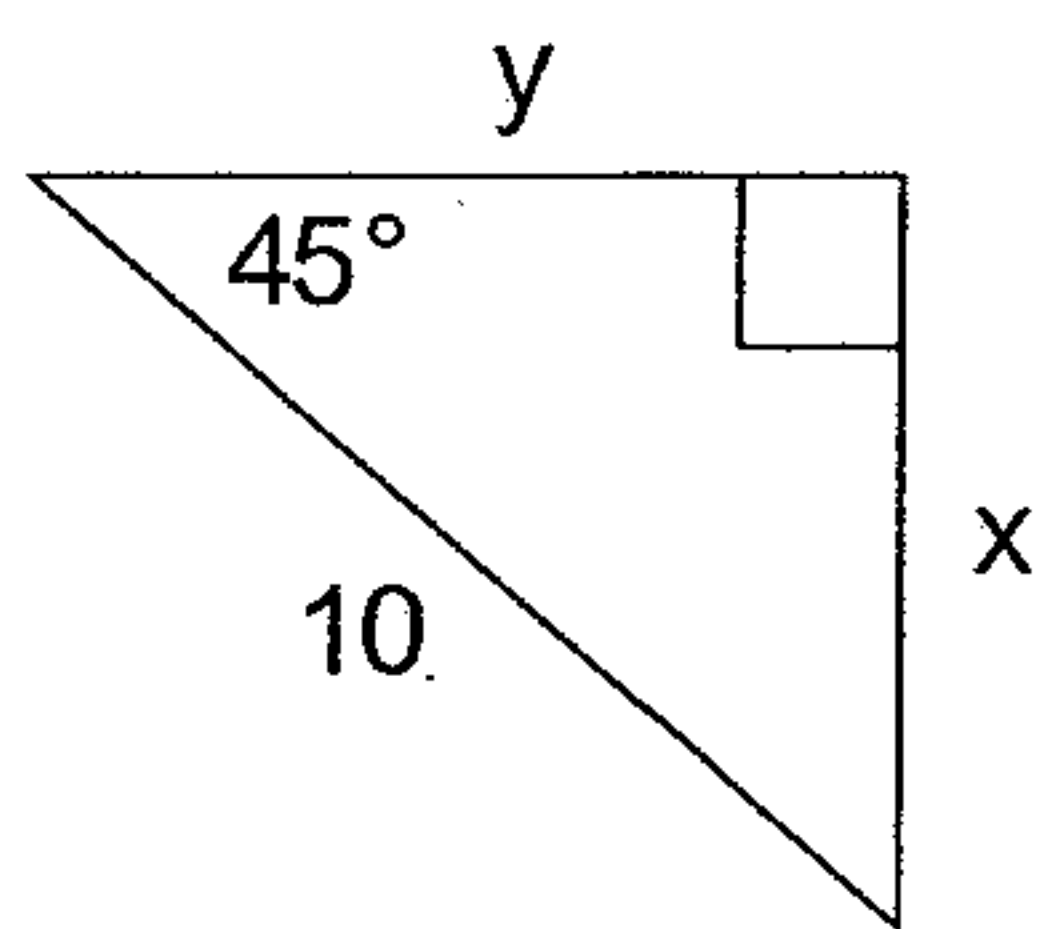

b.

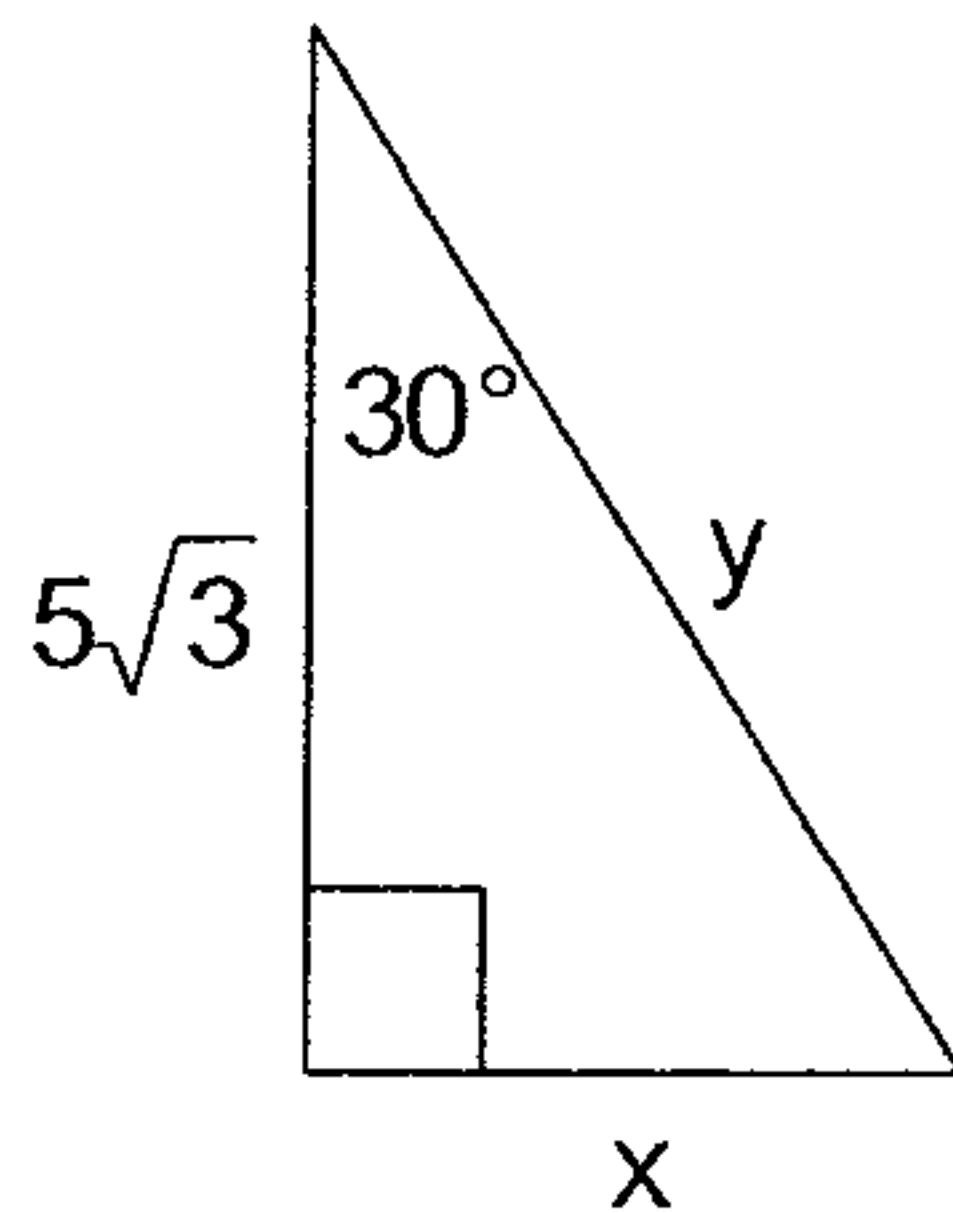

c.

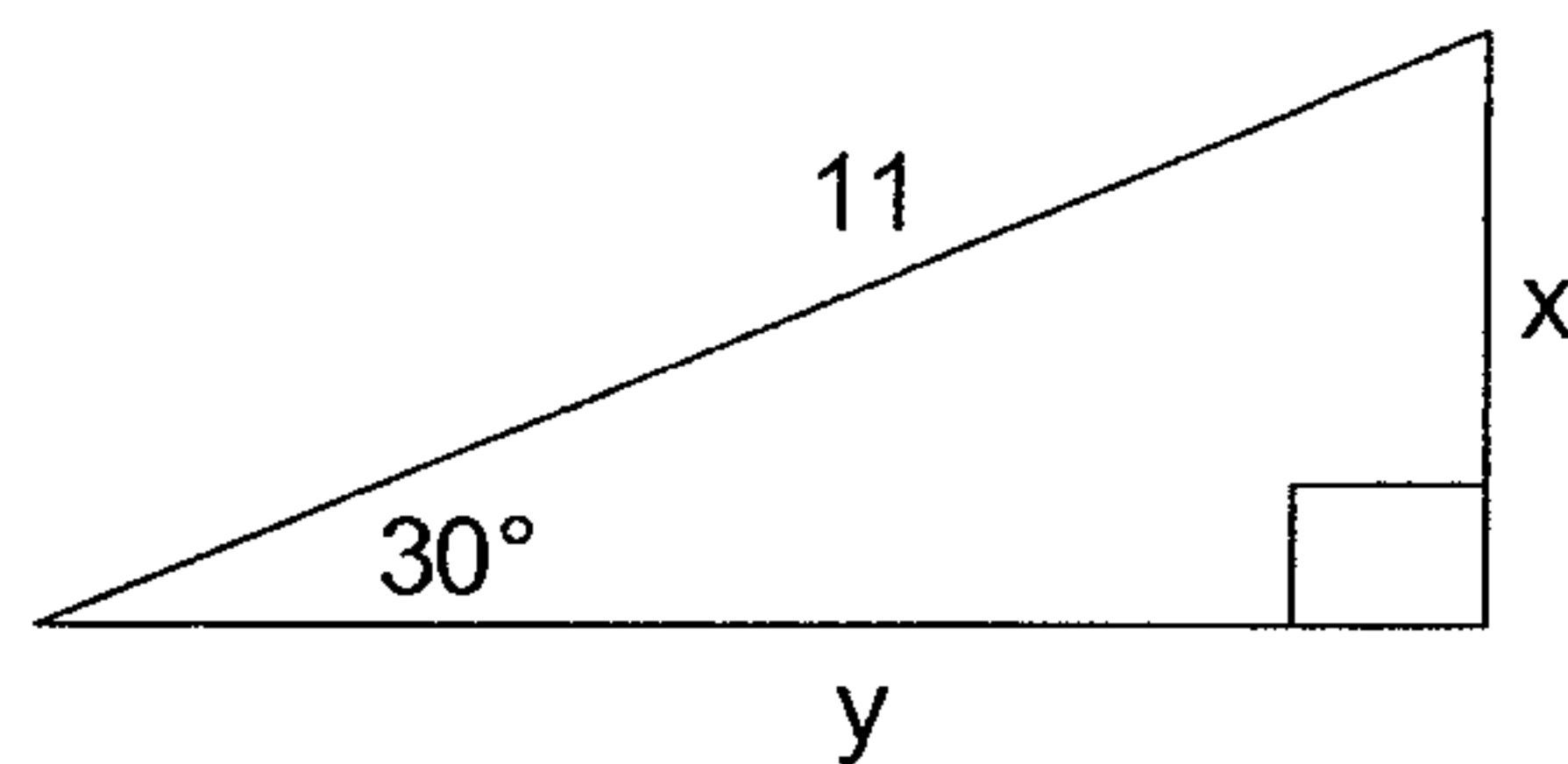

58) Find the missing side.

a.

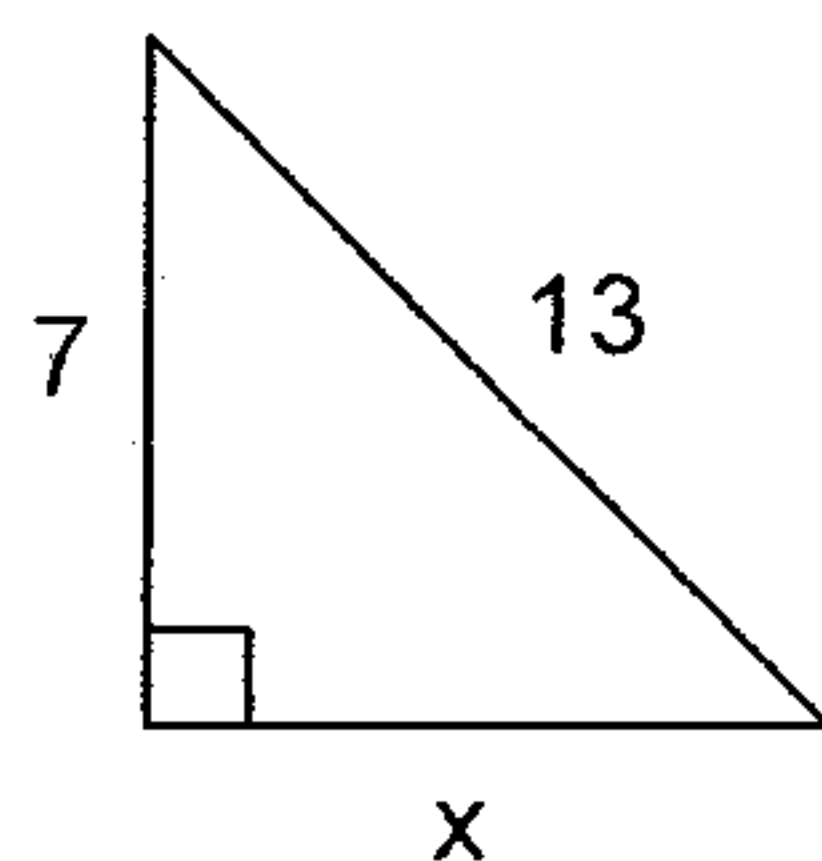

b.

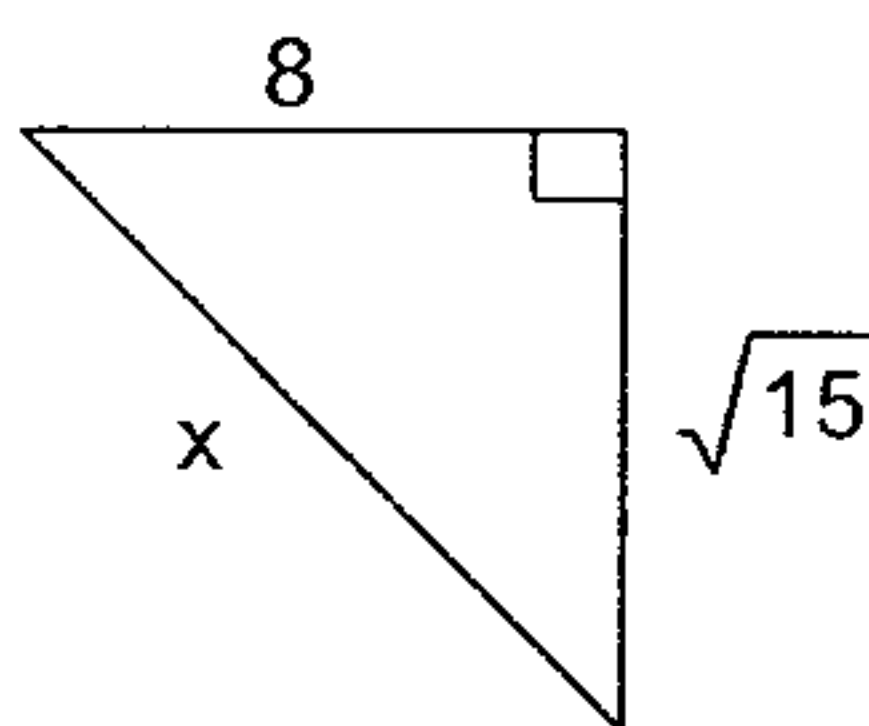

c.

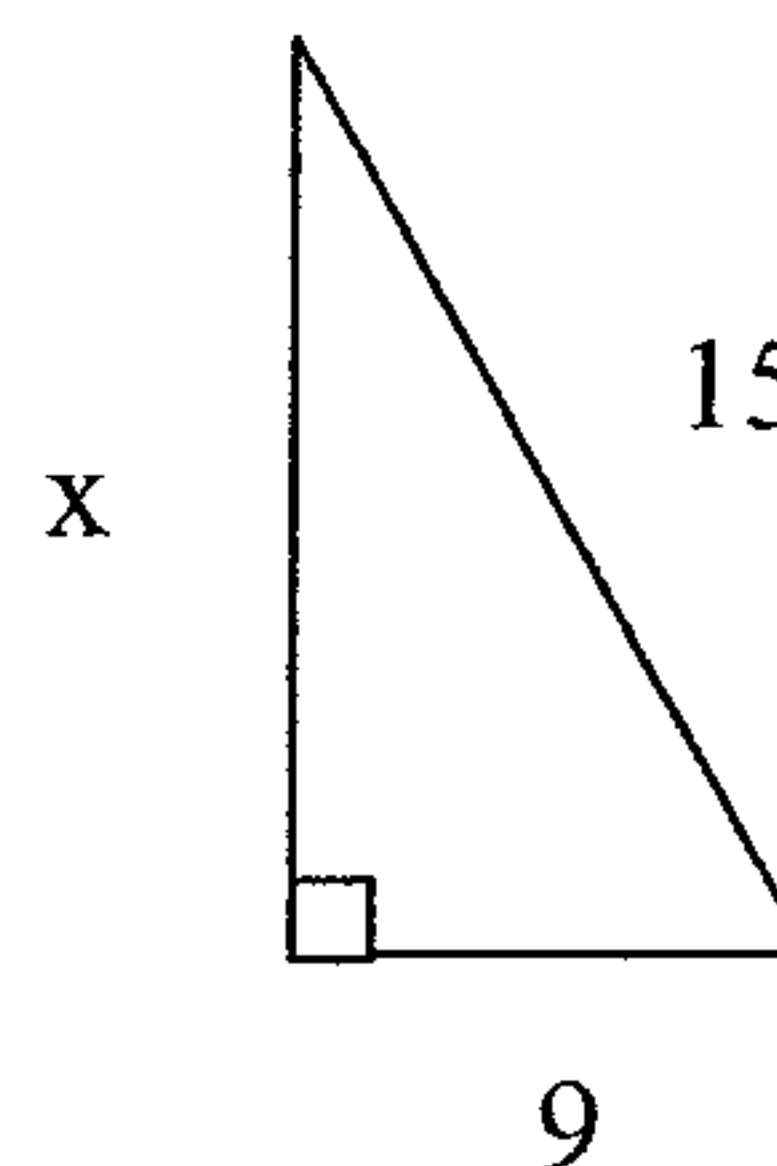

59) If the altitude of an equilateral triangle is  $8\sqrt{3}$ , find the perimeter of the triangle.

60) The length of the median of an equilateral triangle is  $6\sqrt{3}$ . Find the length of a side of the triangle.

61) Two similar triangles have sides in ratio of 8:3.

a. What is the ratio of the corresponding altitudes? \_\_\_\_\_

b. What is the ratio of the perimeters? \_\_\_\_\_

c. What is the ratio of the areas? \_\_\_\_\_

d. What is the ratio of the volumes? \_\_\_\_\_

e. The area of the smaller triangle is 18, find the area of the larger triangle. \_\_\_\_\_